

SUPPRESSION OF TRANSIENT GAIN EXCURSIONS IN EDFA'S

*Comparison of Multiplicative and Additive Schemes for
Combining Feedforward and Feedback Blocks*

Mladen Males, Antonio Cantoni, John Tuthill

*Western Australian Telecommunications Research Institute, 39 Fairway, CRAWLEY WA 6009,
Australia, email: mmales@watri.org.au*

Abstract: In this paper a comparative study of two pump control schemes for suppressing transient gain excursions in EDFA's is presented. The first control scheme is based on the traditional feedforward/feedback control, while the second scheme is new and uses multiplication to combine the feedforward and feedback blocks. The controller parameters are designed using linearised (small-signal) EDFA model derived from the nonlinear state-space model of Bononi and Rusch. When the controller design is applied to the nonlinear EDFA plant, the new scheme is shown to display some important performance improvements over the traditional scheme.

1. INTRODUCTION

Erbium-doped fibre amplifiers (EDFA's) are widely used in multi-channel optical communications systems based on the wavelength-division multiplexing (WDM) technology. The EDFA's are usually operated in deep saturation so that high output powers are achieved. As a consequence, the gain provided by the EDFA to each channel is susceptible to changes in the total input signal power. Transient gain excursions in the surviving channels adversely affect the quality of service that the optical network operators can guarantee [1,2], and these unwanted gain excursions need to be mitigated. In literature, there is a large body of work reported on the transient control of EDFA's (see for example [3–8]). The approaches taken

generally fall into one of the following three groups: pump control [3-5], link control [6] and all-optical control [7,8]. In the work reported in this paper, two schemes for implementing the transient control of EDFA's based on the pump control approach are compared. Both schemes use the closed-loop control architecture of Figure 1 but the difference between the two schemes is in the type of the pump-control block in Figure 1. The two types of the pump-control block are:

- Multiplicative type, where $P_p^{in}(t) = U_{ff}(t)(1 + U_{fb}(t))$
- Additive type, where $P_p^{in}(t) = U_{ff}(t) + U_{fb}(t)$

The additive pump-control block represents the traditional way of combining the feedforward and feedback blocks in the transient control of EDFA's (see for example [3]). The transient control of EDFA's using the closed-loop architecture with the multiplicative pump-control block is investigated for the first time in this paper.

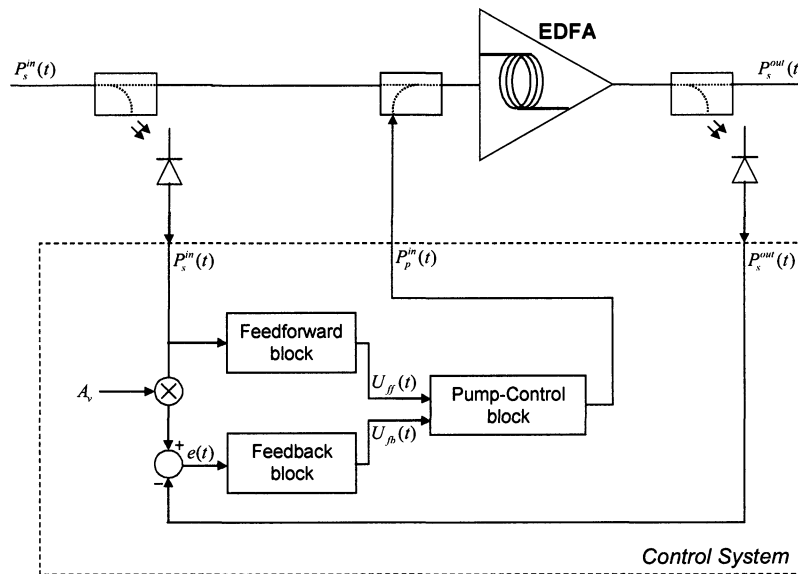

Figure 1. Using measurements of the total input signal power and the total output signal power, the control architecture produces the necessary pump power to maintain the EDFA gain constant. A_v is the desired gain, $P_s^{in}(t)$ and $P_s^{out}(t)$ are the total input and output signal powers, respectively, and $P_p^{in}(t)$ is the EDFA's input pump power.

The feedforward block in Figure 1 realises the following function:

$$U_{ff}(t) = K_{ff} P_s^{in}(t) + O_{ff} \quad (1)$$

For each input signal power there is a corresponding pump power $P_p^{in}(t) = K_{ff}^* P_s^{in}(t) + O_{ff}^*$ that maintains the EDFA gain constant (this fact was utilised in the early successful implementation of the feedforward approach in [5]). The drawback of the feedforward approach is that in practical implementations the exact feedforward parameters K_{ff}^* and O_{ff}^* depend on the EDFA's operating environment. The chosen feedforward parameters K_{ff} and O_{ff} are thus unlikely to produce the exact required pump power [3], and some form of feedback is necessary to provide a corrective action. The feedback block in Figure 1 contains a proportional-integral (PI) controller:

$$U_{fb}(t) = K_p e(t) + K_i \int_0^t e(\tau) d\tau \quad (2)$$

The PI controller reduces the error $e(t)$ to zero in steady state (this is achieved by the integral action [9]) and can be designed to minimise the transient overshoots and undershoots in the output signal power response.

The nonlinear blocks of the closed loop of Figure 1 are the feedforward block, pump-control block (when it is of the multiplicative type) and the EDFA itself. The controller parameters K_{ff} , O_{ff} , K_p and K_i are designed based on linear approximation of the closed-loop system of Figure 1. The controller design is then applied to the nonlinear closed-loop system and the performance of the two schemes is compared.

In the remainder of this report, the design approach is presented for the closed-loop system that includes the multiplicative pump-control block. A similar analysis can also be done for the system with the additive pump-control block but is not included here. Instead, important differences between the two systems are highlighted. An important assumption in the modelling of the EDFA is that the EDFA gain does not vary significantly with wavelength, and hence the total input and output signal power measurements yield sufficient information to keep the gain of each individual channel constant.

2. LINEARISATION OF LOOP COMPONENTS

Under the assumption that the spectral dependence of the EDFA gain is minimal, the EDFA can be modelled by the following nonlinear state-space model [10]:

$$\begin{aligned} \frac{dr}{dt} &= -\frac{r}{\tau} + \left(1 - e^{B_s r - A_s}\right) P_s^{in}(t) + \left(1 - e^{B_p r - A_p}\right) P_p^{in}(t) \\ P_s^{out}(t) &= P_s^{in}(t) e^{B_s r - A_s} \end{aligned} \quad (3)$$

$P_s^{in}(t)$ and $P_s^{out}(t)$ are the total input and output signal powers, respectively, $P_p^{in}(t)$ is the input pump power, r and τ are the total number and the mean lifetime of excited erbium ions, respectively, and B_s , B_p , A_s and A_p are dimensionless constant parameters.

When forming linear approximations of the feedforward block, pump-control block and the EDFA, the input, state and output variables of these blocks are treated as small perturbations around their steady-state values (i.e. a variable $x(t)$ is treated as $x_0 + \delta x(t)$). The linearisation procedure follows that presented in [9], and involves keeping only the linear terms from the Taylor series expansion of nonlinear functions. The Laplace-domain linearised model for the nonlinear blocks of the closed loop of Figure 1 is given below.

$$\begin{aligned} \delta P_s^{out}(s) &= \frac{P_{s0}^{in} e^{B_s r_0 - A_s} B_s \left(1 - e^{B_p r_0 - A_p}\right)}{s + 1/\tau + P_{s0}^{in} e^{B_s r_0 - A_s} B_s + P_{p0}^{in} e^{B_p r_0 - A_p} B_p} \delta P_p^{in}(s) \\ &+ e^{B_s r_0 - A_s} \frac{s + 1/\tau + P_{s0}^{in} B_s + P_{p0}^{in} e^{B_p r_0 - A_p} B_p}{s + 1/\tau + P_{s0}^{in} e^{B_s r_0 - A_s} B_s + P_{p0}^{in} e^{B_p r_0 - A_p} B_p} \delta P_s^{in}(s) \\ &\square \frac{\alpha_0}{s + b_0} \delta P_p^{in}(s) + \frac{a_1 s + a_0}{s + b_0} \delta P_s^{in}(s) \\ &\square G_{sp}(s) \delta P_p^{in}(s) + G_{ss}(s) \delta P_s^{in}(s) \\ \delta U_{ff}(s) &= K_{ff} \delta P_s^{in}(s) \\ \delta P_p^{in}(s) &= U_{fb0} \delta U_{ff}(s) + U_{ff0} \delta U_{fb}(s) \\ &= \left(\frac{K_{ff}^* P_{s0}^{in} + O_{ff}^*}{K_{ff} P_{s0}^{in} + O_{ff}} - 1 \right) \delta U_{ff}(s) + \left(K_{ff} P_{s0}^{in} + O_{ff} \right) \delta U_{fb}(s) \end{aligned} \quad (4)$$

3. CHARACTERISTICS OF LINEARISED CLOSED LOOP

The linear approximation of the closed loop in Figure 1 is shown in Figure 2, where the transfer function of the PI controller is $C(s) = K_p + K_i/s$.

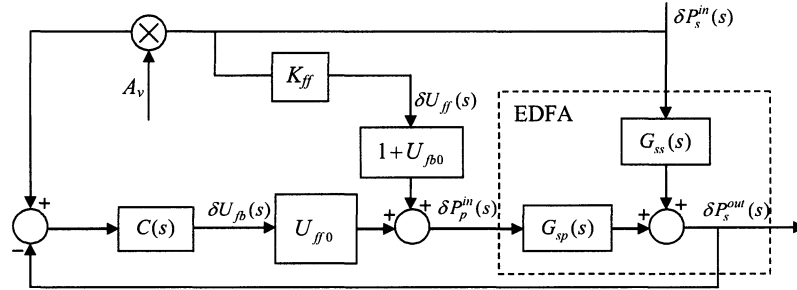

Figure 2. Linear approximation of the closed loop in Figure 1

The transfer function between the input signal perturbation and the output signal perturbation is:

$$T(s) = \frac{\delta P_s^{out}(s)}{\delta P_s^{in}(s)} = A_v \frac{s^2 + \left(b_0 + \frac{K_{ff}^* \alpha_0}{A_v} \left(\frac{(O_{ff}^*/K_{ff}^*) - (O_{ff}/K_{ff})}{P_{s0}^{in} + (O_{ff}/K_{ff})} \right) \right) s}{s^2 + (b_0 + \alpha_0 U_{ff0} K_p) s + \alpha_0 U_{ff0} K_i} + \frac{\alpha_0 U_{ff0} K_p s + \alpha_0 U_{ff0} K_i}{s^2 + (b_0 + \alpha_0 U_{ff0} K_p) s + \alpha_0 U_{ff0} K_i} \quad (5)$$

Whenever $(O_{ff}/K_{ff}) = (O_{ff}^*/K_{ff}^*)$, which occurs either when there is exact knowledge of the ideal feedforward parameters or when the actual feedforward parameters are in error by an equal proportion, the poles and zeros of $T(s)$ coincide and the transfer function reduces to $T(s) = A_v$. This leads to an interesting observation, albeit of limited practical value, that the perfect gain clamping can be achieved even if there are significant errors in the feed-forward parameters, as long as these parameters are erroneous by the same proportion. This is not the case when the pump-control block of Figure 1 is of additive type, as it can be shown that the perfect gain clamping is only obtained when the ideal feed-forward parameters are known exactly.

4. CONTROLLER DESIGN AND PERFORMANCE EVALUATION

For any fixed K_{ff} and O_{ff} , sufficient degrees of freedom exist in the controller to allow K_p and K_i to achieve any desired natural frequency ω_n and damping ξ of the second-order transfer function (5). Similarly, for the closed-loop system that contains the additive pump-control block, it can be shown that for any fixed K_{ff} and O_{ff} , K_p and K_i can be adjusted to produce any ω_n and ξ of the transfer function of the linearised closed loop. In order to compare the performances of the system with the multiplicative pump-control block and the system with the additive pump-control block, a reasonable error is introduced in the feedforward parameters ($K_{ff} = 2.2K_{ff}^*$ and $O_{ff} = 0.8O_{ff}^*$) and K_p and K_i are adjusted in each system to produce $\omega_n = 1 \times 10^{10}$ rad/s and $\xi = 0.707$. The controller design is then applied to the nonlinear closed loop, and the performance comparisons are based on the signal gain and input pump power responses of the nonlinear closed loop.

From Figure 3, the closed-loop system that uses the multiplicative pump-control block is seen to be more effective in minimising the transient gain excursions. The gain excursions are minimal in spite of reasonable input signal power changes and errors in the feedforward parameters.

From Figure 4, it can be seen that when the additive pump-control block is used, the controller can request a negative pump power during the transient period. As this is not physically possible, an additional element is added to the system that clamps the EDFA's input pump power at zero anytime the controller requests a negative pump power. A detrimental effect of the pump power clamping on the transient response is seen in Figure 3, as the largest overshoot/undershoot is observed for the case when the pump power is clamped at zero during the transient period. From Figure 4, it appears that the system with the multiplicative pump-control block is much less likely to produce a negative pump power requirement (compare the curves in Figure 4 for $P_s(\text{new}) = 0.3\text{mW}$).

In Figure 4, the system with the multiplicative pump-control block is also seen to produce smaller transients in the input pump power. This last property is very desirable in practical implementations, as the pump lasers may not be able to produce the high initial powers that the system with the additive pump-control block requests.

From Figure 3 and Figure 4, it can be seen that a close agreement is achieved between the responses of the nonlinear and linearised closed loops. This observation justifies the approach taken to design the controller by linearising the closed loop first.

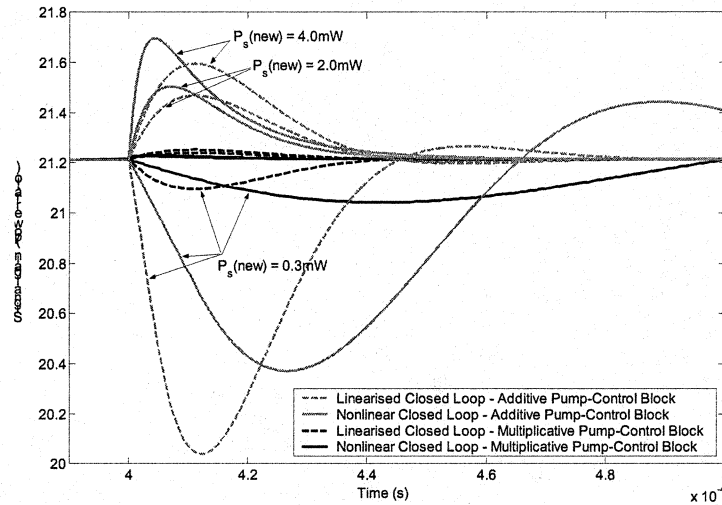

Figure 3. Transient gain excursions after the input signal power is abruptly switched from 1.0mW to a new value. When the pump-control block is multiplicative, the curves for $P_s(\text{new}) = 4.0\text{mW}$ and $P_s(\text{new}) = 2.0\text{mW}$ are almost indistinguishable on this plot.

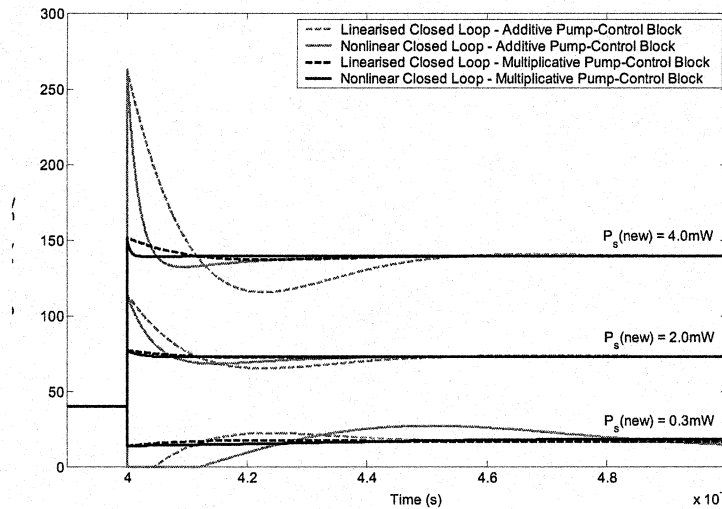

Figure 4. Transient input pump power adjustments after the input signal power is abruptly switched 1.0mW to a new value. When the pump-control block is additive, the curve for $P_s(\text{new}) = 0.3\text{mW}$ reveals that the controller requested a negative pump power (when this happened, an in-loop limiter clipped the input pump power at zero).

5. CONCLUSIONS

From the simulation results presented in this paper, it is evident that the new scheme that uses multiplication to combine the feedforward and feedback blocks has a superior transient performance than the traditional scheme that uses addition. The new scheme is thus more attractive for implementation purposes. Validation of these results on an EDFA hardware platform is currently being conducted as part of this on-going research.

REFERENCES

- [1] A. K. Srivastava et al. "EDFA Transient Response to Channel Loss in WDM Transmission System" *IEEE Photonics Technology Letters*, vol. 9, no. 4, pp. 386–388, March 1997.
- [2] M. I. Hayee and A.E. Willner "Transmission Penalties due to EDFA Gain Transients in Add-Drop Multiplexed WDM Networks" *IEEE Photonics Technology Letters*, vol. 11, pp. 889–891, July 1999.
- [3] C. Tian and S. Kinoshita "Analysis and Control of Transient Dynamics of EDFA Pumped by 1480- and 980-nm Lasers" *IEEE Journal of Lightwave Technology*, vol. 21, no. 8, pp.1728-1734, August 2003.
- [4] M. Karasek and J. C. van der Plaats "Analysis of Dynamic Pump-Loss Controlled Gain-Locking System for Erbium-Doped Fiber Amplifiers", *IEEE Photonics Technology Letters*, vol. 10, no. 8, pp. 1171-1173, August 1998.
- [5] C. R. Giles and E. Desurvire, "Transient Gain and Crosstalk in Erbium-Doped Fibre Amplifiers" *IEEE Photonics Technology Letters*, vol. 2, no. 10, pp. 714–716, Oct. 1990.
- [6] A. K. Srivastava et al. "Fast-Link Control Protection of Surviving Channels in Multiwavelength Optical Networks" *IEEE Photonics Technology Letters*, vol. 9, no. 12, pp. 1667–1669, December 1997.
- [7] D. H. Richards et al. "Multichannel EDFA Chain Control: A Comparison of Two All-Optical Approaches", *IEEE Photonics Technology Letters*, vol. 10, no. 1, pp. 156–158, January 1998.
- [8] A. Bononi and L. Barbieri "Design of Gain-Clamped Doped-Fiber Amplifiers for Optimal Dynamic Performance" *IEEE Journal of Lightwave Technology*, vol. 17, no. 7, pp. 1229–1240, July 1999.
- [9] G. C. Goodwin et al. *Control System Design*. Prentice Hall International, 2001.
- [10] A. Bononi and L. A. Rusch, "Doped-Fiber Amplifier Dynamics: A System Perspective" *IEEE Journal of Lightwave Technology*, vol. 16, no. 5, pp. 945–956, May 1998.