

An Energy*Delay Efficient Routing Scheme for Wireless Sensor Networks

Trong Thua Huynh and Choong Seon Hong

Computer Engineering Department, Kyung Hee University
1, Seocheon, Giheung, Yongin, Gyeonggi 449-701 KOREA
hthua@networking.khu.ac.kr cshong@khu.ac.kr

Abstract. Wireless sensor networks are composed of a large number of sensors densely deployed in inhospitable physical environments. How to disseminate information energy efficiently throughout such a network is still a challenge. Although energy efficiency is a key concern in wireless sensor networks, it often introduces additional delay. In this work, we first propose an Energy*Delay efficient routing scheme called C^2E^2S (Cluster and Chain based Energy*Delay Efficient Routing Scheme) for wireless sensor networks. This scheme is a combination of cluster-based and chain-based approaches. Next, we propose (1) an Energy*Delay-aware routing algorithm for sensors within each k -hop cluster, (2) an Energy-efficient chain construction algorithm for clusterheads. We also consider the network lifetime as an important factor as opposed to other approaches. The simulation results show that C^2E^2S consumes less energy, balances the energy and delay metrics, as well as extends the network lifetime compared with other approaches¹.

1 Introduction

In wireless sensor networks (WSN), where sensors are deployed densely in inhospitable environments, the proximate nodes will sense the identical data. Data aggregation from many of correlative data will reduce a large amount of data traffic on network, avoid information overload, produce a more accurate signal and require less energy than sending all the unprocessed data throughout the network. In various literatures, clustering approach is addressed as a routing method using the data aggregation feature effectively. LEACH [1] is one of the first cluster-based approaches in WSNs. Later, there are many protocols inspired from the idea proposed in LEACH. Works in [9],[11] involved the multi-hop approach into clusters for a larger set of sensors covering a wider area of interest. Many clustering algorithms in various contexts have also been proposed in these literatures, however, most of these algorithms are heuristic in nature and their aim is to generate the minimum number of clusters such that a node in any cluster is at the most d hops away from clusterhead. In our context, generating

¹ This research was partially supported by University ITRC Project. CS Hong is the corresponding author

the minimum number of clusters might not ensure minimum energy usage. In [7], authors have proposed a distributed, randomized clustering algorithm to organize the sensors in clusters. They consider the WSN in which the sensors are distributed as per a homogeneous spatial Poisson process. We use the results of their paper to support to our scheme.

The network lifetime can be defined as the time lasted until the last node in the network depletes its energy. Energy consumption in a sensor node can be due to many factors such as sensing event (data), transmitting or receiving data, processing data, listening to the media (avoid the conflict), communication overhead, etc. Considering the sensor's energy dissipation model in [1], the energy used to send q bits a distance d from one node to another node is given by $E_{tx} = (\alpha_1 + \alpha_2 d^n) * q$. Where α_1 is energy dissipated in transmitter electronics per bit, α_2 is energy dissipated in transmitter amplifier. For relatively short distances, the propagation loss can be modeled as inversely proportional to d^2 , whereas for long distances, the propagation loss can be modeled as inversely proportional to d^4 . Power control can be used to invert this loss by setting the power amplifier to ensure a certain power at the receiver. Obviously, energy consumption in a sensor will be significant if it transmits data to the node that is at long distance. This is one of the reasons that we suggest the k -hop cluster approach. Another reason is that the single-hop cluster approach is suitable only for networks with a small number of nodes. It is not scalable for a larger set of sensors covering a wider area of interest since the sensors are typically not capable of long-haul communication. Moreover, the energy dissipation is uneven in the single-hop cluster approach. In order to improve the energy efficiency, the chain-based approach has been proposed in [3]. In this approach, each node communicates only with a close neighbor and takes turns transmitting to the base station (BS), thus reducing the amount of energy spent per round. However, while chain-based protocols are more energy efficient than cluster-based protocols, they suffer from high delay and poor data fusion capacity.

Motivated by above mentioned issues, in this paper, we propose an energy-delay tradeoff routing scheme: a combination of cluster-based and chain-based approaches for WSNs. Plus, we propose an Energy*Delay-aware routing algorithm and an Energy-efficient chain construction algorithm for sensors within each k -hop cluster. The remainder of the paper is organized as follows: Section 2 mentions about related work. Section 3 and 4 describe the proposed scheme and its operation respectively. Intra-cluster routing algorithm is addressed in section 5 while inter-clusterheads routing is presented in section 6. We present the performance evaluation in section 7. Finally, we conclude the paper in section 8.

2 Related work

Many WSN protocols have been developed for increasing energy efficiency in recent years. A clustering architecture based on the distributed algorithm for WSNs is provided in [1], where sensor nodes elect themselves as clusterheads with some probability based on residual energy of sensors for each round. Al-

though this approach has advantages to using the distributed cluster formation algorithm, it may produce poor clusters throughout the network. In addition, this approach allows only 1-hop clusters to be formed. This limits the capability of protocol. Then, authors improved clustering algorithm by using a center cluster algorithm. In this approach, the BS will control almost all operations in the network including computing and determining optimal clusters. In general, the clusters formed by BS are better than those formed using the distributed algorithm. However, this kind of approach suffers a large number of communication overheads between sensors and BS. Our approach is based on BS. However, to reduce the communication overheads, we propose a modified BS-based approach which will be described in sections 3 and 4.

Clustering architecture introduced in [4] provides two threshold parameters (hard, soft) in order to reduce number of transmission in the networks. The main drawbacks of the two approaches are the overhead and complexity of forming clusters in multi-levels and implementing threshold-based functions. Younis et al. have addressed hierarchical routing architecture in [10] based on 3-layer model. Clusters are formed by a lot of factors such as communication range, number and type of sensor nodes and geographical location, that can base on GPS [8] or other techniques. However, communication from clusterheads to the BS is still direct communication. Besides, authors only focused on the issue of network management within the cluster, particularly energy-aware routing. In [2], authors have provided a protocol called HEED. This approach selects well-distributed clusterheads using information about residual energy and a second parameter such as node proximity to its neighbors or node degree. Authors have presented simulation results in order to prove the energy efficiency compared with other protocols (such as LEACH and its improvements). However, the clustering algorithm in HEED is still heuristic. Besides, HEED also assumes that communication from clusterheads to the BS is 1 hop away. This limits the capability of protocol, especially in large networks.

The approach proposed in [3] to improve the energy efficiency is chain-based approach. In this approach, each node communicates only with a close neighbor and takes turns transmitting to the BS, thus reducing the amount of energy spent per round. However, while chain-based protocols are more energy efficient than cluster-based protocols, they suffer from high delay and poor data fusion capacity. An Energy-Latency tradeoff approach in WSNs has been proposed in [6]. Authors studied the problem of scheduling packet transmission for data gathering in WSNs. They focus on the energy-latency tradeoffs using techniques such as modulation scaling. Although optimal algorithms based on dynamic programming have been proposed, they suffer an exponential complexity.

3 The Proposed Scheme (C^2E^2S)

A proposed network scheme for the WSNs is shown in figure 1. In this scheme, sensors in the WSN are distributed as a homogeneous spatial Poisson process of rate λ in a square area of side a . The computation of the optimal probability p

to becoming a clusterhead and the maximum number of hops k allowed from a sensor to its clusterhead is beyond the scope of this paper. We use the results in [7] to obtain the optimal parameters for our scheme. According to this paper, we determine the maximum number of hops k as follows:

$$k = \lceil \frac{1}{r} \sqrt{\frac{-0.917 \ln(\alpha/7)}{p\lambda}} \rceil \quad (1)$$

Where:

p : optimal probability of becoming a clusterhead

r : transmission range.

α : constant, ($\alpha = 0.001$ used in simulation).

Sensors are distributed into m k -hop clusters using these parameters. Each cluster has a clusterhead that aggregates all data sent to it by all its members. After that, m clusterheads form l binary chains. Each chain divides each communication round into $\log m/l$ levels. Each node transmits data to the closest neighbor in a given level. Only those nodes that receive data can rise to the next level. Finally, leader for each chain sends data to the BS. By then one transmission round completes. In this approach, each intermediate node performs data aggregation.

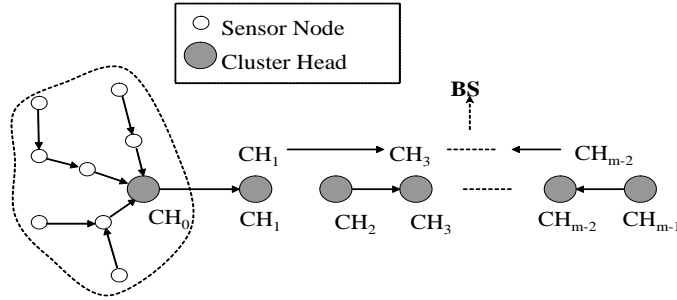

Fig. 1. A combination scheme of cluster and chain based approaches for the WSNs.

In this scheme, cluster and chain formation can either be computed in a centralized manner by the BS and broadcast to all nodes or accomplished by the sensor nodes themselves. To produce the better clusters and chains as well as to remove the strong assumption that all sensors have global knowledge of the network, we use the BS-based approach. However, the centralized approach suffers from very high communication overhead. To deal with this, we propose a passive approach (called passive-BS-based approach) in which each sensor node, upon sending a data packet, piggybacks related information. Upon a data packet reception, the BS extracts this information in order to apply for cluster and chain formation. The data packet format is depicted in figure 2. INFO part is a trio (Node ID, Node Energy, Number of bits). The BS bases on this trio in order

to compute the residual energy for each node. For example, the trio (100, 1.5, 2500) describes that node 100 has 1.5 joules residual energy and sends 2500 bits data to the BS.

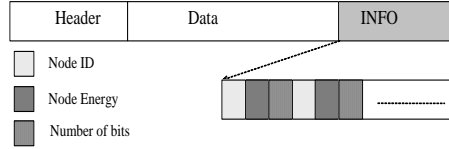

Fig. 2. Data Packet Format. The INFO includes information about ID, Energy, Number of bits of nodes that packet passed.

In this scheme, we assume the sensors are quasi-stationary. Each tiny sensor has a sensing module, a computing module, memory and wireless communication module. The BS has adequate energy to communicate with all sensor nodes in the network. Sensors are left unattended after deployment. They can use power control to vary the amount of transmit power to reduce the possibility of interfering with nearby cluster and its own energy dissipation.

4 C^2E^2S Operation

In C^2E^2S , network lifetime is divided into rounds. Each round begins with cluster and chain formation phase followed by data transmission phase. In each frame of data transmission phase, each sensor node is assigned its own time slot to transmit data to clusterhead. By turn, each clusterhead is also assigned its own slots to communicate with the nearest clusterhead based on chain construction. A detail description is depicted in the figure 3.

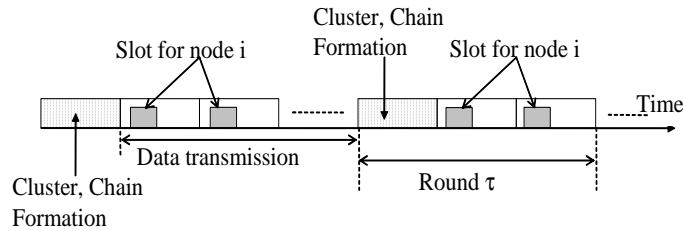

Fig. 3. Network lifetime for C^2E^2S .

Using passive-BS-based approach, C^2E^2S distinguishes between the first round and the remaining rounds. In the first round, all sensors must send in-

formation about their location and current energy level to the BS directly. The BS uses this information and cluster and chain formation algorithms to choose clusterheads, to distribute remaining sensor nodes into associated clusters, and to construct l binary chains among clusterheads. In subsequent rounds, to form clusters and chain, the sensor nodes do not need to resend the information about location and residual energy to the BS anymore. Instead of this, information will be extracted from the INFO part in the data packets received from clusterheads in the previous round. The last packet from each node at the end of each round is the only one that carries information about residual energy level and number of transmitted bits of that node. The other packets carry data normally. Clusterheads receive data packets from other sensor nodes, perform data integration then send data packet to the BS following binary chains.

5 Intra-Cluster Routing

Table 1. Maximum number of hops within each cluster for different network size ($r=1$).

<i>Network size (number of sensors)</i>	<i>Intensity (λ)</i>	<i>Maximum number of hops (k)</i>
1000	10	4
1500	15	3
2000	20	3
2500	25	3
3000	30	3
3500	35	3
4000	40	3

The experiments were conducted for sensor networks of different intensity λ . For each network intensity, we used (1) to calculate the maximum number of hops k allowed from a sensor to its clusterhead. Results are given in Table 1.

From results calculated in Table 1, obviously, 3-hop (at most) cluster is the best choice for the large sensor networks. Plus, the more hops are used, the higher latency is required. Hence, in this section, we propose an Energy*Delay-aware routing algorithm for sensors within each 3-hop cluster instead of k -hop cluster. This reduces significantly the complexity of algorithm compared with other approaches [10, 11]. The 3-hop routing algorithm within each cluster consists of 2 steps as follows:

1. Sensors within each cluster (except the clusterhead) are partitioned into three sets: I, J, K. The detailed algorithm is described in figure 4.
2. Using the Shortest Path Algorithm to determine the best route from these sets of node to clusterhead.

```

# Ei :energy of node i;
# d(i,CHj) : distance from sensor i to clusterhead within cluster j
# Cj : Cluster j   # m : the number of clusters
# z : the number of sensors within each cluster
#I1 ← {} : set of nodes that sense data, relay data from J1, J2 to clusterhead;
#J1 ← {} : set of nodes that sense data, relay data from K to I1;
#I2 ← {}; J2 ← {}; K ← {} : sets of sensing nodes;
#J : union of J1 with J2.      #I : union of I1 with I2.

1.  $CAD = \frac{\sum_{i \in C_j} d(i, CH_j)}{z} \quad \forall i \in C_j, 0 \leq j \leq m-1$  /*average distance from sensors to
associated clusterhead*/
2.  $CAE = \frac{\sum_{i \in C_j} E_i}{z} \quad \forall i \in C_j, 0 \leq j \leq m-1$  //average energy for each cluster;
3. If (d(i,CHj) < CAD) then
If (Ei ≥ CAE) then I1 ← I1 ∪ i;
Else I2 ← I2 ∪ i;
4. Else If (d(i,CHj) ≥ CAD and d(i,CHj) < 2*CAD) then
If (Ei ≥ CAE) then J1 ← J1 ∪ i;
Else J2 ← J2 ∪ i;
5. Else K ← K ∪ i;
6. I ← I1 ∪ I2; J ← J1 ∪ J2

```

Fig. 4. Algorithm - partition sensors into 3 sets of nodes I, J, K.

In step 2, we apply the Shortest Path Algorithm to determine the best route from clusterhead to $J(J_1 \cup J_2)$, K using the set nodes I_1, J_1 respectively.

Our intra-cluster routing problem can be considered as determining the shortest route (least cost) from one node to a set of nodes. We use Dijkstra's algorithm [5] to disseminate data from sensors to clusterhead with the link cost C_{ij} for the link between the nodes i and j defined as follows:

$$C_{ij} = \sum C_k \quad (k = 1..4) \quad (2)$$

Where:

$C_1 = c_1 * d^2(i, j)$: data communication cost (energy) from node i to node j where c_1 is a weighting constant. This parameter reflects the cost of the wireless transmission power. Where $d(i, j)$ is distance between the nodes i and j .

$C_2 = c_2 * d(i, j)$: delay cost because of propagation between the nodes i and j where c_2 is a constant which describes the speed of wireless transmission.

$C_3 = c_3 * E(j)$. This parameter reflects cost of energy, c_3 is a constant. Where $E(j)$ is residual energy of node j .

$C_4 = c_4 * Z(j)$. Where c_4 is a constant, $Z(j)$: number of connections to node j .

6 Inter-Clusterheads Routing

In this section, we provide an Energy-efficient chain construction algorithm for clusterheads. The operation starts with one clusterhead, the farthest clusterhead

from the BS. This node works as the head of the chain. Then, the non-chain node, the one that is closest to the head of the chain, will be appended into the chain. Besides, the BS also takes part in chain construction procedure in order to decide when a chain should be ended. This procedure repeats until all clusterheads are in the chains. The detailed algorithm is described in figure 5. The complexity of this algorithm is $O(n^2)$. This algorithm ensures that clusterheads will communicate with the closest neighbor. Based on the radio energy dissipation model in [1], the receiving cost only depends on packet size, while the transmission energy depends on the distance between two nodes along a chain. As a result, that communication with the closest node is synonymous with consuming the least energy.

```

# CHAIN: chain
#HEAD: the head node in the chain
#d(i,j): distance from node i to node j
1. N: set of clusterheads;
2. HEAD ← The farthest clusterhead from BS,  $\forall$  all nodes  $\in$  N;
3.  $N' \leftarrow N - \{HEAD\}$ ; CHAIN  $\leftarrow \{HEAD\}$ ; EndOfChain  $\leftarrow$  False;
4. While ( $N' \neq \emptyset$ )
   key[i]  $\leftarrow$  min[d(HEAD,i)];  $\forall i \in N'$ ; /* select a clusterhead
                                     i that is closest to the HEAD*/
   If key[i] < d(HEAD,BS);           //BS: base station
     HEAD  $\leftarrow$  i;
   Else {
     HEAD  $\leftarrow$  BS;
     EndOfChain  $\leftarrow$  True;
   }
   Append(CHAIN, HEAD);           // append HEAD at the end of CHAIN
   If (EndOfChain  $\leftarrow$  True) Exit(); // end of While( $N' \neq \emptyset$ ); a chain is
   constructed
5.  $N \leftarrow N - N'$ ;
6. If ( $N \neq \emptyset$ ) Goto 2;      // construct another chain
7. Else Stop;                     // chains are constructed.

```

Fig. 5. Chain construction Algorithm for clusterheads.

7 Performance Evaluation

In this section, we analyze the performance evaluated against LEACH-C, H-PEGASIS (Hierarchical PEGASIS), and HEED protocols in terms of communication overhead, the number of communication rounds (network lifetime), total amount of energy dissipated in the system over time, network delay and Energy*Delay metric using a simulator based on SENSE [12].

7.1 Simulation Setup

Our sensor field spans an area of $100 \times 100 m^2$ wherein 2000 sensors are scattered randomly with the BS location at (75,125). A node is considered "dead" if its energy level reaches 0. For a node in the sensing state, packets are generated at a constant rate of 1 packet/sec. For the purpose of our simulation experiments, the values for the parameters c_k in the link cost C_{ij} (given by (2)) are initially picked based on sub-optimal heuristics for best possible performance. The communication environment is contention and error free; hence, sensors do not have to retransmit any data. To compute energy consumption for each transaction sending and receiving, we use the radio energy dissipation model in [1]. The energy used to transmit q -bit data a distance d for each sensor node is: $E_{Tx}(q,d) = qE_{elec} + q\varepsilon_{fs}d^2$. The energy used to receive data for each node is: $E_{Rx}(q) = qE_{elec}$. Where E_{elec} is the electronics energy, ε_{fs} is power loss of free space. In these experiments, each node begins with 2 joule of energy and an unlimited amount of data to be sent to the BS. Table 2 summarizes parameters used in our simulation.

Table 2. Simulation Parameters.

<i>Parameter</i>	<i>Value</i>
Network size	100x100
Number of sensors	2000
Base station location	(75,125)
Packet generating rate	1 packet/sec
E_{elec}	50nJ/bit
ε_{fs}	10pJ/bit/m ²
Initial energy (for each node)	2 Joule
Data packet size	500 bytes
Header size	25 bytes
Info packet size	25 bytes
Cluster Info packet size	50 bytes

7.2 Simulation Results

For the first experiment, comparing the efficiency of network lifetime between the existing protocols and C^2E^2S , we studied the number of communication rounds as number of dead nodes increase and the total energy dissipated upon number of communication rounds. The graph in figure 6.a compares the network lifetime among LEACH-C, H-PEGASIS, HEED and C2E2S. In C^2E^2S , sensor nodes consume energy more evenly than other approaches. Although k -hop cluster approach in C^2E^2S suffers slightly higher delay, it balances energy dissipation between sensor nodes. Thus, number of communication rounds increase significantly. Compared with LEACH-C and HEED, C^2E^2S balances energy consumption between clusterheads. Compared with H-PEGASIS, C^2E^2S reduces a large number of identical data bits between sensors in the same cluster. Figure

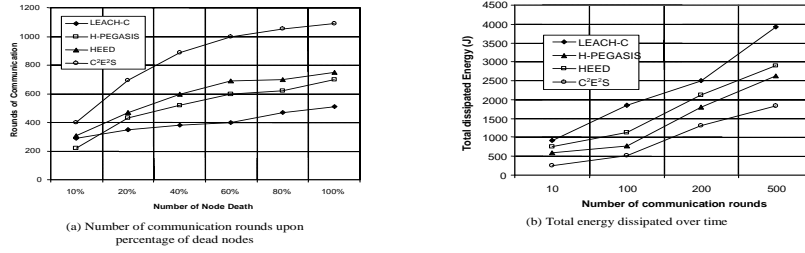

Fig. 6. Comparing the efficiency of network lifetime among protocols.

6.b shows the amount of energy dissipated after a number of communication rounds. C^2E^2S is able to keep its energy dissipated gradually thus prolonging network lifetime.

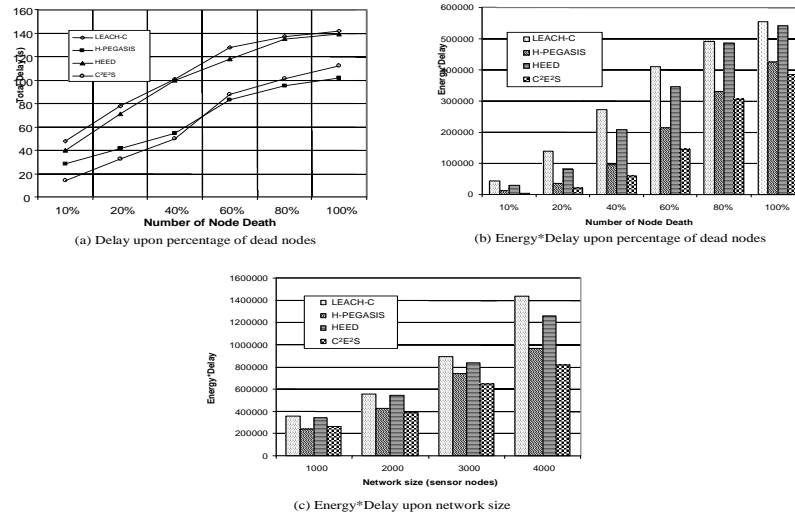

Fig. 7. Comparing the efficiency of Energy*Delay metric among protocols.

For the second experiment, we first evaluate network delay metric. Next, to calculate the Energy*Delay, we multiply the total delay with total dissipated energy over time for each protocol. The graph in figure 7.a shows that the network delay in LEACH-C is the highest while C^2E^2S offers the lowest delay. However, when the number of dead nodes increases a lot, the network delay in C^2E^2S is slightly higher than H-PAGESIS. Regardless of this, C^2E^2S saves much more energy than H-PEGASIS. Thus, Energy*Delay metric in C^2E^2S is always lower

than H-PEGASIS. As shown in figure 7.b, this metric is also lower than in both LEACH-C and HEED (cluster-based approaches).

Besides, to indicate the effectiveness of our scheme in terms of Energy*Delay metric for large sensor networks, we ran several simulations with different network sizes (from 1000 to 4000 sensors). Figure 7.c shows that when network size increase, the effectiveness of Energy*Delay metric in our scheme also increases significantly. For 1000 sensor nodes, C^2E^2S is slight higher than H-PEGASIS. However, for more than 2000 sensor networks, Energy*Delay in C^2E^2S is lower than other protocols. Hence, we can say that, C^2E^2S is a very Energy*Delay efficient scheme for large WSNs.

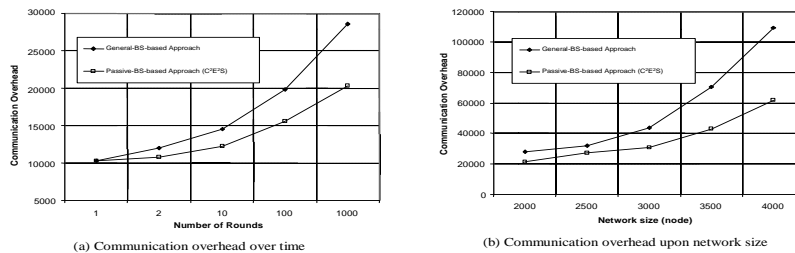

Fig. 8. Communication overhead for Gen-BS-based and Passive-BS-based approaches.

In the last experiment, we studied the communication overhead as total number of header bits transferred from sensors to the BS. In our approach, node's information is piggybacked by data packets. Thus, it reduces a large number of communication overheads broadcasting through the network using general BS-based approaches (we call Gen-BS-based approach). Figure 8.a shows that the number of communication overheads is equal in the first round for both the approaches. However, from the second round, the number of communication overheads increases gradually in C^2E^2S , while Gen-BS-based approach (LEACH-C, HEED) increase very fast.

The effectiveness of C^2E^2S is seen more clearly as there are several simulations run for a large number of sensor nodes. Yet again, we compare two approaches for different network sizes (from 2000 to 4000 sensors). Result in figure 8.b shows that the number of communication overheads increases very fast in Gen-BS-based approach, while it increases gradually as number of sensor nodes increases.

8 Conclusion

Motivated by delay- awareness energy efficiency, in this paper, we have presented an Energy*Delay routing scheme (called C^2E^2S) for WSNs. We also

have proposed two algorithms in order to balance the energy and delay metrics for all sensors in the network, extend lifetime of network and reduce the number of communication overheads in the network. One of these algorithms is Energy*Delay routing algorithm. This algorithm is applied within 3-hop cluster in order to balance energy*delay for sensors within each cluster. Another algorithm is Energy-efficient chain construction algorithm. This algorithm is applied for clustered heads to construct energy-efficient chains from clusterheads to the BS. Simulation results demonstrate that C^2E^2S consistently performs well with respect to Energy*Delay-based metric, network lifetime, and communication overhead compared with other approaches. As a future work, we need study on energy*delay optimal routing to improve the goodness of our scheme.

References

1. W. R. Heinzelman, A. Chandrakasan, H. Balakrishnan, "An Application-Specific Protocol Architecture for Wireless Microsensor Networks", in IEEE Transactions on Wireless Communications, October 2002.
2. O. Younis, S. Fahmy, "HEED: A Hybrid, Energy-Efficient Distributed Clustering Approach for Ad hoc Sensor Networks", in IEEE Transactions on Mobile Computing, October 2004.
3. S. Lindsey, et al., "Data Gathering Algorithms in Sensor Networks using Energy Metrics", in IEEE Transactions on Parallel and Distributed Systems 2002.
4. A. Manjeshwar, D. P. Agrawal, "APTEEN: A Hybrid Protocol for Efficient Routing and Comprehensive Information Retrieval in WSNs", in the Proceedings of IEEE IPDPS 2002.
5. F. Zhan, C. Noon, "Shortest Path Algorithms: An Evaluation Using Real Road Networks", Transportation Science, 1996.
6. Y. Yu, B. Krishnamachari, V. K. Prasanna, "Energy-Latency Tradeoffs for Data Gathering in Wireless Sensor Network", in Proceedings of IEEE INFOCOM 2004.
7. S. Bandyopadhyay and Ed. J. Coyle, "An Energy Efficient Hierarchical Clustering Algorithm for Wireless Sensor Networks", in Proceedings of IEEE INFOCOM 2003.
8. US Naval Observatory (USNO) GPS Operations, <http://tycho.usno.navy.mil/gps.html>.
9. K. Dasgupta, K. Kalpakis, P. Namjoshi, "An Efficient Clustering-based Heuristic for Data Gathering and Aggregation in Sensor Networks", in Proceedings of WCNC 2003.
10. M. Younis, M. Youssef, K. Arisha, "Energy-Aware Routing in Cluster-Based Sensor Networks", in the Proceedings of IEEE MASCOTS'02, October 2002.
11. Alan D. Amis, Ravi Prakash, Thai H.P. Vuong, Dung T. Huynh, "Max-Min D-Cluster Formation in Wireless Adhoc Networks", in Proceedings of IEEE INFOCOM 2000.
12. Gang Chen, et al., "SENSE - Sensor Network Simulator and Emulator", <http://www.cs.rpi.edu/~cheng3/sense/>.