

Fuel Cell Systems for Telecommunications

Eunice Ribeiro¹, António Cardoso¹ and Chiara Boccaletti²

¹ University of Coimbra, FCTUC/IT
Department of Electrical and Computer Engineering
Pólo II – Pinhal de Marrocos, P – 3000-290, Coimbra, Portugal
Phone/Fax number: +351 239 796 232/247,
eribeiro@co.it.pt, ajmcardoso@ieee.org

²Sapienza University of Rome
Department of Electrical Engineering
Via Eudossiana, 18, 00184 Rome, Italy
Tel: (+39) -06-44585762, Fax: (+39)-06-4883235,
chiara.boccaletti@uniroma1.it

Abstract. Standalone power systems for telecommunications are becoming an emergent need, due to environmental problems and their current tendency to be localized in remote places. Along with photovoltaic and wind generators, fuel cells are one of the most mature technologies to be employed in this kind of systems. As they are expensive and complex systems, it is important to simulate their behaviour to study different operating modes. This paper intends to propose a simulation of a fuel cell system with a voltage-fed full-bridge converter in the Matlab-Simulink[®] environment fulfilling the strict telecommunications equipment requirements.

Keywords: Telecommunications power system, fuel cell, dc-dc converter.

1 Introduction

Due to the attention to environmental concerns that has been increasing at a worldwide level and the proliferation of telecommunications equipment in remote places, one of the best choices for the future of the telecommunications power supply systems is based on renewable energies applied to stand-alone power systems. This kind of power systems combines a set of different renewable energies to guarantee an autonomous and sustainable operation with a reduced need of maintenance, suitable for supplying remote telecommunications equipment. The majority of standalone power systems are based on wind and photovoltaic generators. These kinds of generators are intermittent and, consequently, it is necessary to include energy storage systems to balance the energy production during periods of low solar radiation or wind speed.

In combination with solar or wind generators, fuel cells associated to electrolyzers and hydrogen tanks are a good solution to store energy, as an alternative to the most standard batteries, because they increase the system availability while reducing its maintenance costs.

This paper intends to present the simulation of a fuel cell system operation, where the included DC-DC converter plays a very important role to fulfill the telecommunications equipment requirements. The simulation has been performed as closely as possible to actual conditions, using dynamic models of fuel cells. Different operating modes are studied and compared to the telecommunications requirements verifying the excellent performance of the fuel cell to supply this kind of equipments.

2 Contribution to Technological Innovation

Since telecommunications equipments are being organized in dispersed networks, reliable remote power solutions are emerging as a critical need, where a backup system like a fuel cell combined with an electrolyzer and a hydrogen tank has a vital role. The proposed simulation permits to improve the application of fuel cells as a backup in these kinds of systems, since the power electronics interface simulation is included and different modes of operation can be designed and studied in advance.

The DC-DC converter employed in this simulation is different from the usual ones, which are simple topologies without galvanic isolation [1-6]. Indeed, in order to fulfill the telecommunications equipment requirements, galvanic isolation is required. At low power levels, simple, non-isolated topologies are commonly used, such as buck, boost and buck-boost [7]. Their topologies include an electronic switch, an inductor to store energy, and a flywheel diode [8]. The electronic switch commutation is controlled in order to maintain the required load voltage. The flywheel diode carries the current during that part of switching cycle when the electronic switch is off.

Higher levels of power (above 1 kW) require isolated topologies, e. g. flyback, forward, push-pull, half-bridge and full-bridge. These are more complex topologies, but, once again, the load voltage depends on the switching control of the electronic switches [8]. Fuel cells brought other challenges to power electronics like the need for low input current ripple, in order to reduce the ripple of the stack voltage and this is why current-fed converters are usually specified as a good power electronics interface for them [7]. The study of these kinds of converters as power electronics interfaces between the fuel cell and the load is usually performed through analytical calculations to describe their operating behaviour [9] or simulations with usual DC voltage sources instead of fuel cell system models as this paper proposes [10]. The advantages of such a study are obvious. Fuel cell systems are expensive and complex and, therefore, they need to be carefully designed and studied before their implementation, especially for high power applications or critical applications where uninterruptible power is required.

The converter chosen for this system was the voltage-fed full-bridge converter. According to [11], where a mathematical analysis is presented as a criterion to choose the most efficient and appropriated DC-DC converter for fuel cells applications, the voltage-fed full-bridge converter is the most efficient DC-DC converter with galvanic isolation and it needs the least core cross section of the transformer. The input current ripple is low [7].

3 Fuel Cell System Simulation

The aim of the proposed simulation is to study the dynamic performance of a fuel cell system composed only by a fuel cell carefully dimensioned and a power electronics interface capable of maintaining the required telecommunications equipment voltage. As it was already explained, telecommunications power systems must obey to strict power requirements and, due to this, power converters play a very important role in this kind of systems. The importance of the power converters simulation increases when a not yet consolidated technology to produce electrical power, such as fuel cells, is used.

The fuel cell model and its parameters were taken from [1-6] and they have been used to simulate innumerous standalone applications like portable equipments (laptops, for example) [1], residential houses [2, 3], vehicles [4], and hybrid power generation plants [5, 6]. The model has been implemented in the Matlab-Simulink[®] environment, as shown in Fig.1.

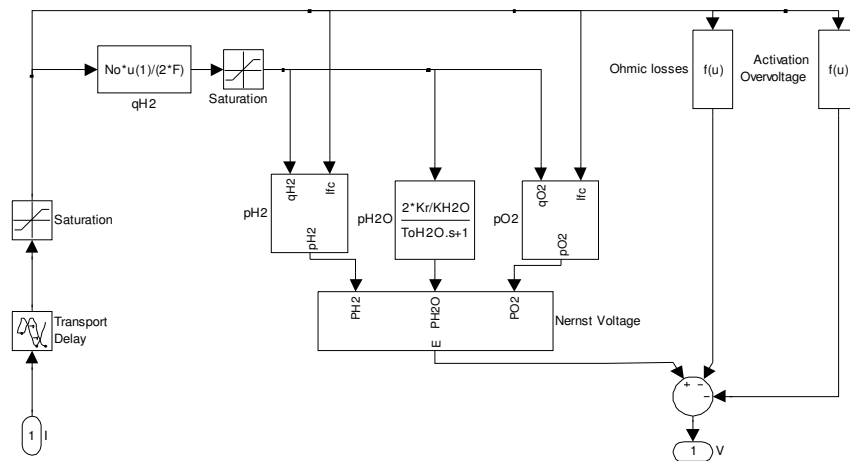

Fig. 1. Fuel cell system Simulink[®] model.

The required amount of hydrogen q_{H_2} [kmol (s)⁻¹] that is consumed by the fuel cell is related to the stack current I (A) by [1-6]:

$$q_{H_2} = \frac{N_o I}{2F} \tag{1}$$

where N_o is the number of cells in series in the stack and F is the Faraday's constant.

This value allows calculating the partial pressure of hydrogen (p_{H_2}), oxygen (p_{O_2}) and water (p_{H_2O}), which are important to obtain the Nernst voltage, given by:

$$E = N_o \left[E_o + \frac{RT}{2F} \log \left[\frac{p_{H_2} \sqrt{p_{O_2}}}{p_{H_2O}} \right] \right] \tag{2}$$

where E_o is the no-load voltage [V], R is the universal gas constant and T is the stack temperature [K].

The stack output voltage V is

$$V = E - B \ln(C \times I) - R \times I \tag{3}$$

where B and C are constants to simulate the activation overvoltage in the fuel cell system [1-6] and R is the internal resistance of the fuel cell stack [Ω].

The whole simulation system is presented in Fig. 2.

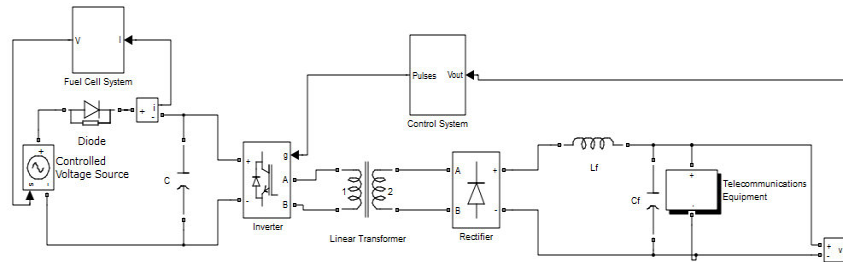

Fig. 2. Fuel cell system Simulink[®] model with power electronics interface and telecommunication equipment.

The modeled telecommunication equipment is a Radio Base Station (RBS). The model includes resistances and switches aiming to simulate load variations, as shown in Fig. 3. A typical RBS load has a nominal power of 3 kW and an overload (until 4 kW) is imposed to study the transient behaviour of the system in case of load variations. Its nominal operating voltage range is 48 V and the operating voltage ranges from 42.75 V to 56.7 V [12].

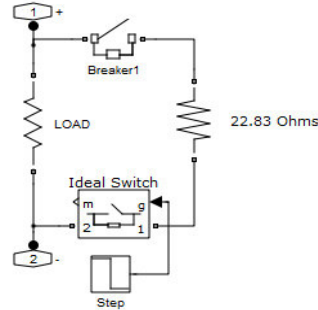

Fig. 3. Simulink® load model.

4 Simulation Results

The dynamic performance of the fuel cell is tested under a load variation of 33%, applied between 0.3 and 0.6 seconds, which is shown in Fig. 4.

In Fig. 5, the output stack voltage is shown and a voltage ripple of 1.5 V is visible. During the increase of power, the voltage ripple also increases to 2 V. As it can be seen in Fig. 6, the voltage is always kept under the required levels for telecommunications equipment with a reduced ripple of 0.4 V, even in presence of the transients caused by the turn-on of the system or the power variations. A LC filter was used, with a capacitor of 200 μF and an inductance of 2 mH. When the load power increases, the voltage reduces to 37.6 V during the 15 ms transient as it can be seen in detail in Fig. 7. At 0.6 seconds, an overvoltage of 60.7 V is caused by the load power decreasing again to the nominal value (Fig. 8). Also this transient takes 15 ms.

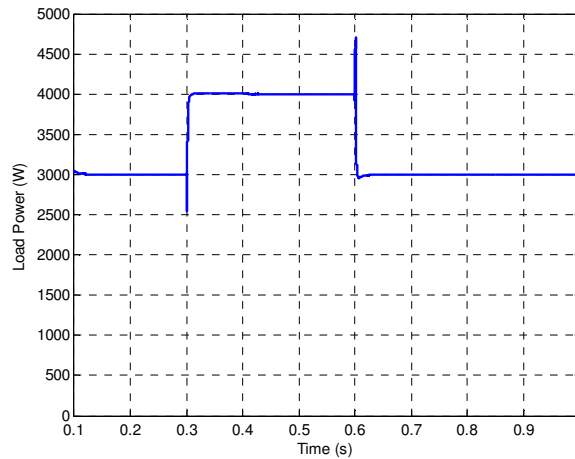

Fig. 4. Simulink® load model: Load Power.

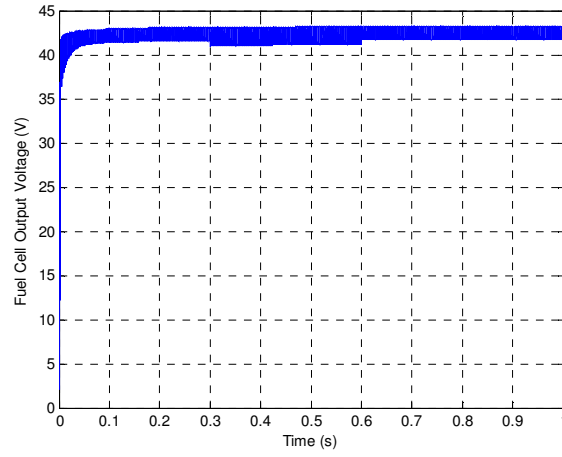

Fig. 5. Simulink[®] load model: Fuel Cell Output Voltage.

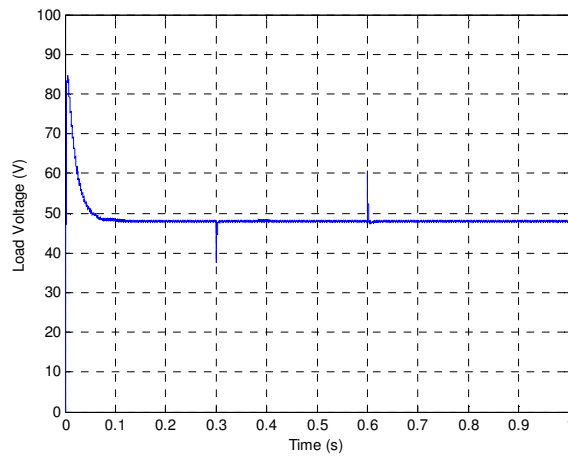

Fig. 6. Simulink[®] load model: Load Voltage.

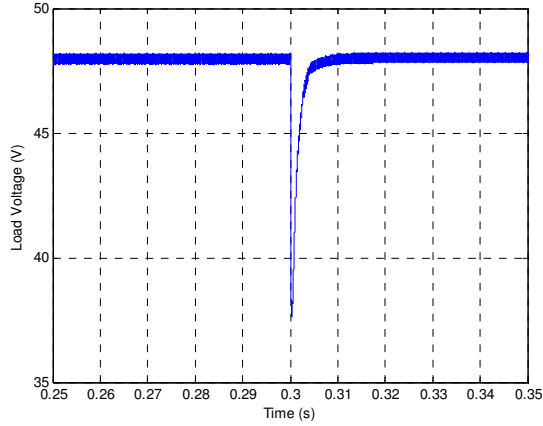

Fig. 7. Simulink© load model: snapshot of Load Voltage curve.

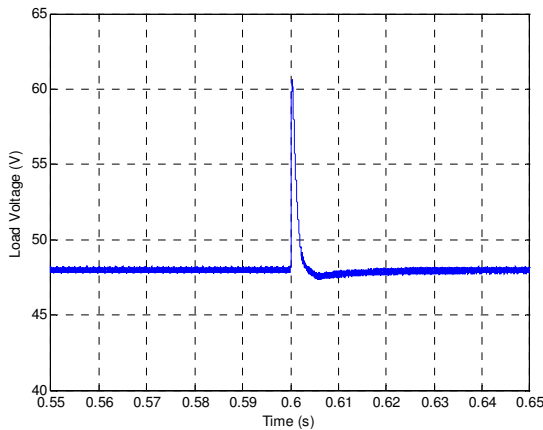

Fig. 8. Simulink© load model: snapshot of Load Voltage curve.

5 Conclusion

Telecommunications equipments are strictly exigent on their requirements, such as establishing dc nominal voltage, keeping voltage at its operating level and assuring a reduced ripple and noise in voltage and current waveforms. The presented results of the simulation show how effective the chosen fuel cell system is in fulfilling the load requirements. The present work permits to improve the application of fuel cells as a backup device, since the power electronics interface simulation is included and different modes of operation can be designed and studied in advance.

Directions for future work, include the implementation of a complete standalone power system model of which the fuel cell system will be a part. Mathematical models of the different system components (photovoltaic and wind generators) will be

interconnected and a supervisory control system will be developed to define the interaction among them. The most important objective of this control system is to supply the load at its full demand while monitoring the pressure in the hydrogen storage tank. To design such a control system is a challenging task that requires the definition of monitoring key system parameters to be compared one with another to transmit the precise commands, allowing the accomplishment of the load requirements. The conceived fuel cell system model already takes these parameters into account. Further work will be done to achieve a more complex and reliable system. For example, a supercapacitor could be added to the fuel cell system in order to improve its dynamic response.

Acknowledgments. This work was partly supported by Fundação para a Ciência e a Tecnologia (FCT) under Project No. SFRH/BD/47741/2008 and Project No. SFRH/BSAB/950/2009.

References

1. Yalcinoz, T., Alam, M. S.: Improved dynamic performance of hybrid PEM fuel cells and ultracapacitors for portable applications. *International Journal of Hydrogen Energy* 33, pp. 1932--1940 (2008)
2. El-Sharkh, M.Y., Rahman, A., Alam, M.S., Byrne, P.C., Sakla, A.A., Thomas, T.: A dynamic model for a stand-alone PEM fuel cell power plant for residential applications. *Journal of Power Sources* 138, pp. 199--204 (2004)
3. Uzunoglu, M., Alam, M.S.: Dynamic modeling, design, and simulation of a combined PEM fuel cell and ultracapacitor system for stand-alone residential applications. *IEEE Transactions on Energy Conversion* 21, pp. 767--775 (2006)
4. Uzunoglu, M., Alam, M.S.: Dynamic modeling, design and simulation of a PEM fuel cell/ultra-capacitor hybrid system for vehicular applications. *Energy Conversion and Management* 48, pp. 1544--1553 (2007)
5. Onar, O.C., Uzunoglu, M., Alam, M.S.: Dynamic modeling, design and simulation of a wind/fuel cell/ultra-capacitor-based hybrid power generation system. *Journal of Power Sources* 161, pp. 707--722 (2006)
6. Uzunoglu, M., Onar, O.C., Alam, M.S.: Modeling, control and simulation of a PV/FC/UC based hybrid power generation system for stand-alone applications. *Renewable Energy* 34, pp. 509--520 (2009)
7. Kirubakaran, A., Jain, Shailendra, Nema, R. K.: A review on fuel cell technologies and power electronic interface. *Renewable and Sustainable Energy Reviews* 13, pp. 2430--2440 (2009)
8. Mohan, N., Undeland, M., Robbins, W.: *Power Electronics Converters, Applications and Design*. John Wiley & Sons, USA (2003)
9. Averberg, A., Mertens, A.: Analysis of a voltage-fed full bridge DC-DC converter in fuel cell systems. In: *Power Electronics Specialists Conference*, pp. 281--292 (2007)
10. Kovacevic, G., Tenconi, A., Bojoi, R.: Advanced DC-DC converter for power conditioning in hydrogen fuel cell systems. *International Journal of Hydrogen Energy* 33, pp. 3215--3219 (2008)
11. Krykunov, O.: Comparison of the DC-DC converters for fuel cell applications. *International Journal of Electrical, Computer, and Systems Engineering* 1, p. 71--79 (2007)
12. Reeve, D. W.: *DC Power System Design for Telecommunications*. John Wiley and Sons, USA (2007)