

Design and Implementation of Parent fish Breeding Management System Based on RFID Technology

Yinchi Ma^{1,2}, Wen Ding^{1,2}

1 Beijing Fisheries Research Institute, Beijing, 100068, China

2 National Engineering Research Center of Freshwater Fisheries, Beijing, 100068, China

Abstract. In the breeding process of high quality economy parent fish, the identification and the information storage and management of the parent fish are often through artificial way. This way takes workload too much and is hard to get high reliability. It is difficult to track and manage the breeding process of the parent fish well for us. Based on the RFID (Radio Frequency Identification, RFID) technology, we developed a parent fish breeding management system which can greatly reduce the artificial workload and realize the reliable management and tracking for the breeding process of the parent fish. Test and analysis results show that the RFID Read-Write Handle-net with the antenna of 25 cm or 40 cm diameter can read and write the glass label in the muscle of the parent fish with the average distance of 16.41 cm ~ 22.82 cm. Under the support of the software system, we can realize the reliable management and tracking for the breeding process of the parent fish. The design and realization of the system have a important significance for the factory breeding of the parent fish.

Key words: RFID, parent fish breeding, identification, storage, transmission, management, tracking

1 Introduction

Modern aquaculture is gradually changing to facilities and factory model. Requirements for automation and information management are improving continuously now. Especially for breeding process of some high quality economic mother fish, due to the high value individual, the long breeding cycle, the recognition, storage, transmission, management and trace work of the physiology and other

¹ Ma Yinchi (1982 -), Beijing Fisheries Research Institute, Engineer, Master, graduated from Beijing Normal University, State Key Laboratory of Remote Sensing Science, mainly engaged in research of agriculture remote sensing and fisheries information technology.

attributes information become very important. During the past long-term process of breeding, the recognition of the mother fish is usually through the artificial means. And the breeding worker traces and notes the key information in the notebook. Even by using the computer technology, we are also failure to form a system of management. It is difficult to trace and investigate the whole breeding process of the mother fish effectively, and often wastes effort.

RFID (Radio Frequency Identification) is a kind of non-contact automatic Identification technology began to be popular since the 1990s. The basic principle is to realize the target automatically by using radio frequency signals and space coupling (inductor or electromagnetic coupling) transmission characteristics. One identification system based RFID is usually consists of four parts including the host machine, the RFID read-write equipment, the RFID tag and the antenna. The system can work without manual intervention, and do well job in many bad environment. RFID is able to identify the fast-moving objects and multiple tags. RFID can realize the information storage and transmission of the target, and the operation is fast and simple. If RFID can work cooperate with the management information system, we can realize the automatic and intelligent information management for the target. For the mother fish, the tag will work in the body of it, the RFID technology can be qualified for the management and tracing of the breeding processing information. At present, in the logistics, tobacco management, experimental animal management and other areas, there have been some mature applications. In the factory aquaculture field, RFID technology is also used in traceability operation for the breeding objects, and has achieved good results. Combining with the actual demand of the mother fish breeding, we design and realize a mother fish breeding management system based on RFID technology. This system realizes the whole processing of identification, storage, transmission, management and tracing of the mother fish. The system will promote the automation informatization level of the mother fish breeding, and bring a important significance for the breeding of the high quality economy mother fish.

2 Materials and methods

The glass tube RFID tag will be injected in a fixed subcutaneous muscle position of the parent fish. The RFID Read-Write Handle-net can identify the individual information of the parent fish automatically. The information will be transmitted to

the PDA or portable notebook computer through the Blue-Tooth. And then the information will be transmit to the center server computer installed the breeding management system of the parent fish through the wireless network. The management system will establish a independent electronic files for every parent fish, and realize the fine management and tracing back of the whole breeding process of every parent fish. The structure of the system is shown as below (Fig.1).

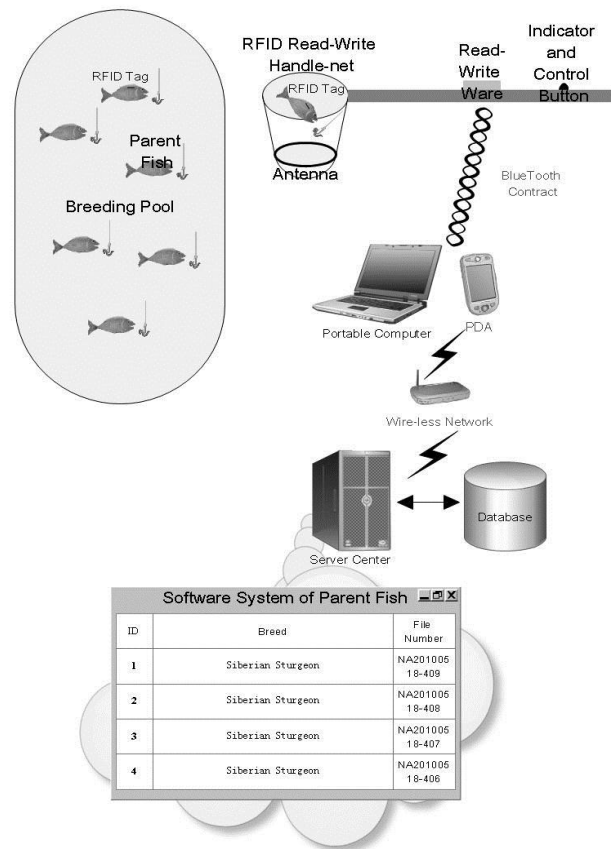

Fig. 1. System Diagram

Because the popular Read-Write ware usually uses TI or PHILIPS CMOS chip, such as EM4095, the emission power was limited when the CMOS chip was produced. The Read-Write ware cannot recognize the tag with a longer distance. This way has many limits in some special areas. In this article, the operation of identification and Read-Write is always done in the water, at the same time, the tag is small and the parent fish is usually big, so the Read-Write distance between the tag antenna and the

CMOS chip must be limited. We design the RFID Handle-net, the communication method and the management software for the breeding demand. The major function of the system shows below.

The first, the system realizes the Handle-net identification, so the parent fish need not to be pulled out of the water, and the damage can be reduced to be the most few.

The second, the identification can be very fast, the RFID Handle-net can identify and read-write data during 3~5 minutes.

The third, the operation is simple, and one operator can finish the whole work. The RFID Handle-net works following the normal work mode, and this way has a big signification for popularization.

The forth, the system uses the wire-less communication way, and the PDA or portable computer can work in the breeding place conveniently.

The last, the system realizes the whole noting of the parent fish, and establishes the electrical file for each one. So we can manage and tracing back the whole breeding information of every parent fish.

The key technology of the system is the RFID Read-Write Handle-net. Low frequency tag can sent back the information automatically when the power big enough given by the reader. In order to read and write the information with a long distance, the read-write equipment must give the power big enough. At the same time, the noise from the read-write equipment must be small, so that the feeble signal can be received. The system uses the glass tube tag equipped with 125KHz chip. The length of the tag is 12mm and the diameter of it is less than 2mm. This kind of tag can stay in the muscle stably and safely. The injection method is convenience and safely, and the parent fish cannot be hurt. This way has been implied in many areas such as aquiculture and circulation of high quality fish. The technology is much mature now. For the design of RFID Handle-net, we use the components separate method, so as to enlarge the emission power of the read-write equipment and improve the receiving precision. At the same time, we did the special design for the antenna. We use the way of rolling cuprum line to produce the antenna and realize the average read-write distance of 16.14cm~22.82cm by diameter 25cm circle antenna, and the average read-write distance of 16.95~22.09cm by diameter 40cm circle antenna.

The structure diagram of the RFID Read-Write Handle-net is shown as below (Fig.2).

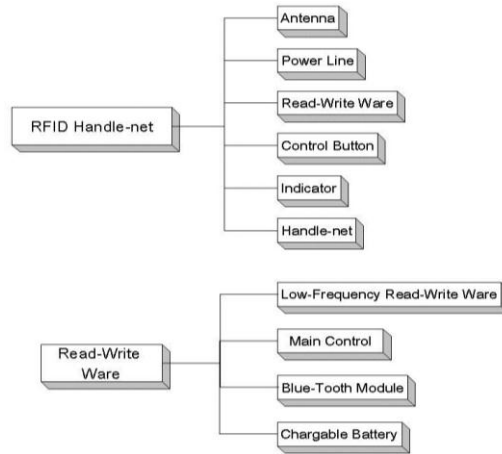

Fig. 2. Structure Diagram of RFID Read-Write Handle-net

The key technology of the RFID Read-Write Handle-net is the validity of the big power identification ware and the antenna when work in the water.

For the effect of multi-antenna identification, we use the components separate method. The power of the CMOS chip can be promoted to two Watt, so that the function of the equipment can reach the best effect (Fig.3).

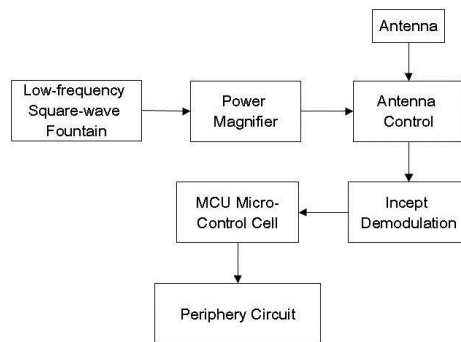

Fig. 3. High power multi-channel identifier

The multi-route read-write ware with big power is according to the 11784/11785 protocol completely. And it gets the information from the glass tube tag by signal emission, channel selection and signal receiving.

The system software is developed based on VC++ platform and SQL server database, including three parts, such as PDA\portable computer windows client module and database management server module. The architecture scheme of the software is shown as below (Fig.4).

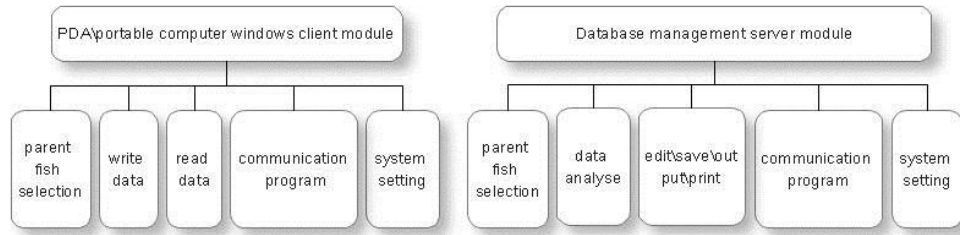

Fig. 4. Architecture scheme of the software

The whole breeding information can be found in the database by the parent fish selection module. Data can be read and written between the tag and the system by the read data and the write data module. Users can analyze the parent fish breeding data by math method through the data analyse module, and check all the life parameter of the parent fish. So users can finished the tracing job. The Bluetooth and WIFI connection and transmission can be done by the communication program. The data management server also can deal the edition, saving, outputting and printing online for the parent fish information. Users can set the system personally by the system setting module.

The interface of the system software is designed compactly, conveniently and friendly. The software function is accord with the need of aquiculture. With the data analyse module, users can check the life and breeding data of the parent fish in time, for example, year of the parent fish, data of its body, pedigree of its family, information of its breed, complexion of feeding, note of propagation, digital case history and so on. Through the analysis by math method, system can give fine data support for aquiculture management. And users can finish the tracing job during the whole breeding process for every parent fish.

The system uses Bluetooth and WIFI communication technology. Bluetooth is used for communication with a short distance. And otherwise, WIFI is used for communication with middle and long distance. Through WIFI network, uses can gather in-phase information from any breeding pool to the information center far away from locale.

The key of the system test is the effect of the RFID Read-Write ware. In the XiaoTangshan experiment base of Beijing Fisheries Research Institute, we took experiment with twelve Koi parent fish. We injected the tag into the muscle under the dorsal fin of every parent fish. Then we tested the RFID Read-Write ware with diameter 25cm and 40cm separately, and received good results. Following the practice requirement, we design three groups of experiment.

The tag moves on the center point line of the antenna circle. The diagram shows as follow (Fig.5).

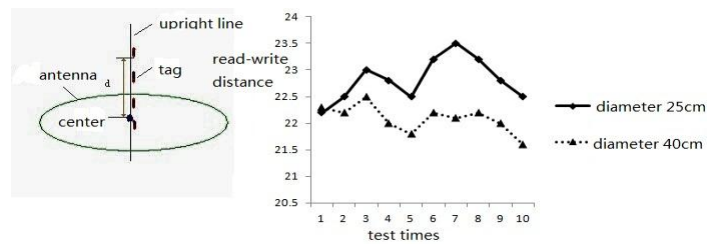

Fig. 5. Test 1 for RFID Read-Write Handle-net

The test results show that, the average read and write distance of the diameter 25cm antenna is 22.82cm, and the max distance reach to 23.5cm. the average read and write distance of the diameter 40cm antenna is 22.09cm, and the max distance reach to 22.5cm. When the tag go into the area of the antenna by the way, the effect of the diameter 25cm antenna is better than that of the diameter 40cm antenna.

The tag moves on the center line between the center of the circle and the edge of the circle. The diagram shows as follow (Fig.6).

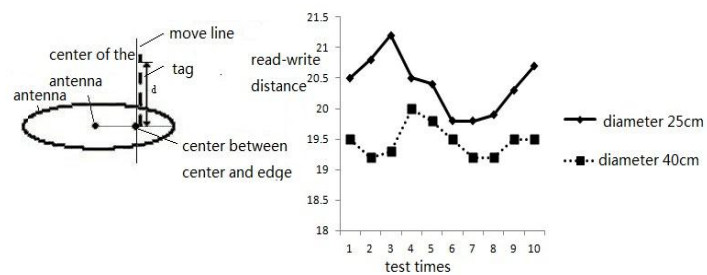

Fig. 6. Test 2 for RFID Read-Write Handle-net

The test results show that, the average read and write distance of the diameter 25cm antenna is 20.39cm, and the max distance reach to 21.2cm. the average read and write

distance of the diameter 40cm antenna is 19.47cm, and the max distance reach to 20cm. When the tag go into the area of the antenna by the way, the effect of the diameter 25cm antenna is better than that of the diameter 40cm antenna.

The tag moves on the line through the point on the edge of the circle. The diagram shows as follow (Fig.7).

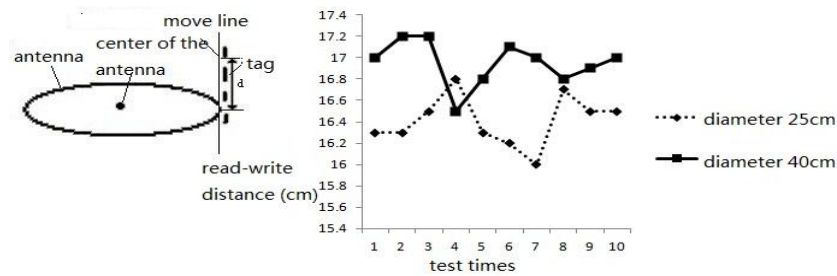

Fig. 7. Test 3 for RFID Read-Write Handle-net

The test results show that, the average read and write distance of the diameter 25cm antenna is 16.41cm, and the max distance reach to 16.8cm. the average read and write distance of the diameter 40cm antenna is 16.95cm, and the max distance reach to 17.2cm. When the tag go into the area of the antenna by the way, the effect of the diameter 25cm antenna is worse than that of the diameter 40cm antenna.

3 Conclusions

The test results from parent fish breeding site show that, RFID Read-Write Handle-net can read and write the data of the tag in the parent fish muscle steadily and veraciously when the tag move in the projection column of the antenna plane among the average distance 16.41cm and 22.82cm. In practice, users can select diameter 25cm or 40cm type antenna due to the complexion. At the same time, we have done the union test with the hardware and software of the system, the data communication state is steady and terminal test is also good for using.

In this article, we use some high value parent fish such as the Koi and the surgeon as research our object. In practice, the breeding technician can read and write the breeding information, physiological information and quality information of the parent fish automatically and conveniently by using this system. And then they set up database to manage all the information digitally. They can form the scientific breed

aquatics project by the tracing information of every parent fish. This method can give ample and credible data support for gene optimization and quality upgrading of the high value parent fish. At the same time, the design target of this system is to provide a new technology method for the high value parent fish breeding. The application environment and effect have a little limit. Design and implementation for other worse breeding environment are emphases of the next step research.

Reference

1. Xu Wang. Theory and Practice of Parent Fish Breed Aquatics [J]. Aquiculture. 2004, 12:28-31. Chinese reverse to English.
2. Zhao Bin, Zhang Hongyu. Application and development of RFID technique [J]. Electronic Design Engineering. 2010, 18(10):123-126. Chinese reverse to English.
3. Shen Jijun. RFID technology and Analysis of the key technology [J]. China Computer & Communication. 2010, 3:146-147. Chinese reverse to English.
4. Wang Zhiqiang, Liu Wenxia. The Application of electronic tag in logistics control system and the design of anti Jamming [J]. Micro Computer. 2005, 21(7-3):154-156. Chinese converse to English.
5. Jin Kangfu. Design and Implementation of Tobacco Input/output Warehouse Management System Based on RFID [J]. Computer Knowledge and Technology. 2011, 7(4):813-816. Chinese converse to English.
6. Wen Zefeng, Xia Long, Qi Changyong, etc. The Application of Radio Frequency Identification (RFID) in the Management of SPF Laboratory Animals [J]. LABORATORY ANIMAL SCIENCE. 2010, 27(3):36-38. Chinese converse to English.
7. Chen Meihua. Application of RFID Technology in Farm Produce Code-Chain Logistics [J]. JOURNAL OF YUEYANG VOCATIONAL TECHNICAL COLLEGE. 2011, 26(5):79-82. Chinese converse to English.
8. Shi Bing, Zhao De'an, Liu Xingqiao, etc. Application of intelligent system based on traceability and wireless sensor network to industrial aquaculture [J]. Fishery Modernization. 2011,38(1):24-27. Chinese converse to English.