

Research on control system of variable rate fertilizer applicator in precision farming based on combined positioning of GPS, electronic compass and gyroscope

Guobing Pan^{1,2} Xiao Feng²

(1 Structure Engineering Lab, Chongqing Jiaotong University, No.66 Xuefu Road Nan'an District Chongqing China ,China,400074)

(2 School of Civil Engineering & Architecture, Chongqing Jiaotong University, No.66 Xuefu Road Nan'an District Chongqing China ,China,400074)

Abstract.On the Background of precision farming and the precision positioning of variable rate fertilization, the precision farming was achieved and the per unit yield was raised by the integrated positioning method using GPS, electronic compass, and gyroscope.

Keywords:Precision farming; combined positioning; variable rate fertilization.

1. Introduction

China is a great agricultural country, but in a situation of large population with relatively little land. Arable land resources limited, however, China feeds 22% of the world's population with less than 10% of the land in the world. With the rapid development of science and technology, the introduction and experiment of the concept of precision farming, and the new challenges of the traditional fertilization systems, exploration has been made domestically and abroad^[1,2]. Precision fertilization is only part of precision farming, but with a undefined concept and immature theory and technical system.This paper mainly discussed about the theory and technical system of combined positioning method based on GPS, electronic compass and gyroscope.

2. Outline of Precision farming and the main technological ideas

2.1 Meaning of Precision farming

Precision farming is a modern and meticulous agriculture technology, which based on modern information high-tech and equipment engineering technology.It basically means to adjust the crop input according to soil properties of the crop. In another words, on one hand it finds out the soil properties insides the plot soils and the space mutation of the productivity. On the other hand, it makes certain of the production target and conducts system diagnostic, optimizing formula, technical assembly, and scientific management firmly, so that it can mobilize the soil

The fund of structure engineering of chongqing jiaotong university (CQSLBF-Y011-4)

The fund of experiment teaching and reform of chongqing jiaotong university(SY1201003)

productivity to get equal or higher output with the least or the most economical input, and improve the environment to make the economic benefits and environmental benefits with all kinds of agricultural resources efficiently^[3,4].

2.2 Main technological ideas of precision farming

Precision farming includes aspects such as precision seeding, precision fertilization, precision irrigation and precision harvest. However, the development of precision agriculture makes a new requirement for theory and technical of rational fertilization. From the use of fertilizer, the contribution rate on food production is 40%; but the utilization rate of nitrogen is only 50%, phosphorus 30% and potassium 60% even in countries which owns a high fertilizer utilization rate. Low utilization rate of fertilizer makes a higher producing cost, and leads to environmental issues, such as the pollution of underground and surface water, and excessive content of nitrate in fruits and vegetables. In a word, fertilization is closely relevant to agricultural production, product quality, and food and environmental pollution. And the theory and technology of precision fertilization is the key solution^[5].

3. Necessity of precise fertilization

The relationship of soil, crop and nutrient is very complicated. Although the necessary major elements and micro-elements during the growth of crop have been fixed, the degree of nutrient which crops need varies from different plants. The difference in nutrient demands can be great in different growing seasons even for the same crop. Seedling stage is a temporary nutrition period for crop. In this period, there is less requirement for the quantity of nutrient, but the demand of nutrient must be complete, effective and adequate. Many crops need a certain kind of most and best nutrient in the most efficient period of nutrient. The most efficient period of different nutrients for the same crop can be different, and it is also the same with different crops. Different nutrients are irreplaceable, namely, the crop production is limited by the least nutrient which can not be replaced by other nutrients. What is more, the overuse of fertilizer to eliminate restrictions of minimum nutrient rate brings a series of environment problems. Therefore, in order to adapt to different regions, different crops, different soil and different environment for various crops, and to achieve good economic benefit and environmental benefits, variable rate fertilizing is absolutely the key development direction of fertilization in the future^[6,7].

4. Integrated positioning method based on GPS, electronic compass and gyroscope

4.1 Combined positioning

It is required for precision fertilization that the agricultural machinery should work on the prearranged route in the field, reach its destination accurately and then complete the work. Precision guiding is one of the key technologies to automate the agricultural machinery, and the positioning accuracy of it directly affects the path tracking of the agricultural machinery. Thus the adoption of efficient and reliable navigation and positioning accuracy should be put to the priority to ensure the path following of agricultural machinery and realize the precision of automatic fertilization. The positioning of agricultural machinery includes heading information and location information. In the respect of navigation technology which mainly based on GPS, RTK-GPS and FOG are taken for existing researches to realize the positioning of the agricultural machinery, but it is of high cost. This paper used GPS of low cost and precision, combined with electronic compass and high accuracy inertial navigation system, to achieve the Precise positioning of agricultural machinery by Kalman filtering, as shown in Fig.1.

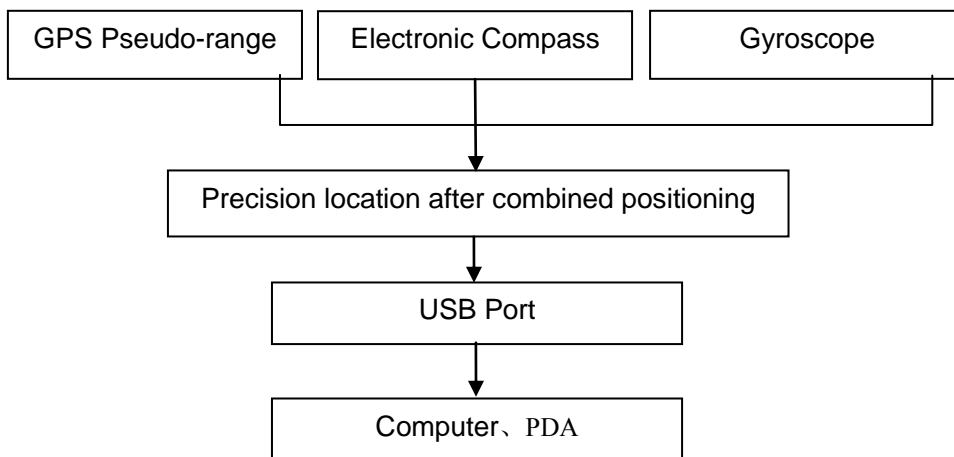

Fig.1 The figure of combined positioning

4.2 Idea of realizing combined positioning

1) Firstly, use pseudo-range difference GPS method to locate the primary location of agricultural machinery.

GPS receiver calculates the WGS-84 coordinates by pseudo-range difference. However, the fertilizer application machine uses Gauss plane coordinates, so Gauss projection should be made to convert the coordinates of pseudo-range positioning to Gauss plane coordinates.

2) Use electronic compass and micromachined gyroscope to measure the heading angle of fertilizer application machine, and to predict the best heading angle.

① The heading angle of electronic compass and gyroscope can be set as x_d and x_t ; the corresponding error are v_d 、 v_t ; covariances of x_d and x_t are r_{dd} and r_{tt} ; the covariance is r_{dt} ; the time evaluation of rth sampling is $r_{dd}(r)$; the time evaluation of r_{tt} is $r_{tt}(r)$; and the time evaluation of $r_{dt}(r)$ is $r_{dt}(r)$. Time evaluation of r_{dd} 、 r_{tt} and r_{dt} of pre-sampling can be calculated by equations below.

When $r < N$

$$R_{dd}(r) = \frac{k-1}{k} R_{tt}(r-1) + \frac{1}{k} (x_d - u)(x_t - u) \quad (1)$$

$$R_{tt}(r) = \frac{N-1}{N} R_{dd}(r-1) + \frac{1}{N} (x_t - u)(x_d - u) \quad (2)$$

$$R_{dt}(r) = R_{dt}(k) = \frac{k-1}{k} R_{dt}(r-1) + \frac{1}{k} (x_d - u)(x_t - u) \quad (3)$$

When $r > N$

$$R_{dd}(r) = \frac{N-1}{N} R_{tt}(r-1) + \frac{1}{N} (x_d - u)(x_t - u) \quad (4)$$

$$R_{tt}(r) = \frac{N-1}{N} R_{dd}(r-1) + \frac{1}{N} (x_t - u)(x_d - u) \quad (5)$$

$$R_{dt}(r) = R_{dt}(k) = \frac{N-1}{N} R_{dt}(r-1) + \frac{1}{N} (x_d - u)(x_t - u) \quad (6)$$

In the equation above, μ is average sample data, and "N" is displacement distance of window.

② Measurement variance δ_d^2 、 δ_t^2 of electronic compass and gyroscope can be calculated by equations below.

$$\delta_d^2 = R_{dd} - R_{dt} \quad (7)$$

$$\delta_t^2 = R_{tt} - R_{dt} \quad (8)$$

③ Heading angle "X" can be calculated by equation below.

$$X = \frac{x_d}{\delta_d^2 \left(\frac{1}{\delta_d^2 + \delta_t^2} \right)} + \frac{x_t}{\delta_t^2 \left(\frac{1}{\delta_d^2 + \delta_t^2} \right)} = \frac{\delta_d^2 x_t + \delta_t^2 x_d}{\delta_t^2 + \delta_d^2} \quad (9)$$

3) Use adaptive Kalman filter to recombine and amend the multi-source information including the primary location and the heading angle, locate agricultural machinery and precisely evaluate the heading angle information.

5. Conclusion

This research realized the precision positioning of agricultural machinery, ensured the principal issue of path tracking quality, and finally achieved the accuracy of automatic fertilization. The precise position after integrated positioning was sent to computer or PDA through USB port. Combined with the data of fertilizing and the field position information from the database, the goal of variable rate fertilization was finally reached, precision farming was realized, and the per unit yield was raised.

Reference

1. Blackmore BS. Precision farming: An introduction. *Outlook on Agriculture*. 1994 23:275~280. CABI.
2. Blackmore BS. An information system for precision farming. Presented at the Brighton Conference Pests and Diseases. British crop Protection Council. November P18-21, 1996.
3. Lal R. Soil management in the developing countries[J]. *Soil Science*, 2000, 165(1): 57-72.
4. Pan Jianjun, Fang Shibo, Sun Weixia, Chen Liyan. A preliminary study on rice nitrogen application decision-making by soil information system — A case study of Dafeng City, Jiangsu Province[J]. *JOURNAL OF NANJING AGRICULTURAL UNIVERSITY*, 2000, 23(3): 53-56.
5. Meng Zhijun, Zhao Chunjiang, Liu Hui; Huang Wenqian, Fu Weiqiang; Wang Xiu. Development and performance assessment of map-based variable rate granule application system[J]. *Journal of Jiangsu University(Natural Science Edition)*, 2009, 30(4): 338-342.
6. SUN Zhi-guo, YU Feng, ZHENG Chuan-tao, REN He. Design of CPLD Control Module of GPS Variable Fertilization System[J]. *Journal of Agricultural Mechanization Research*, 2008(3): 83 -86.
7. Li Aichuan, Wang Xi, Wang Zhiqiang, Gao Fei. Research about Variable Rate Fertilization Closed-loop Control System of Electro-hydraulic Speed[J]. *Chinese Agricultural Science Bulletin*, 2009, 25(07): 272-275.