

# Automatic Control System for Highway Tunnel Lighting

Shijuan Fan<sup>1</sup>, Chao Yang<sup>1</sup>, Zhiwei Wang<sup>1</sup>

**Abstract.** In order to solve the problems of large energy consumption existing in tunnel lighting control system, an automatic control system of tunnel lighting is designed based on stepless control method. The tunnel lighting control model is established based on “Specifications for Design of Ventilation and Lighting of Highway Tunnel (China)”. Simulation of tunnel lighting control based on the established stepless control model is completed with Matlab. Compared with theoretical luminance data, simulation results show that the automatic control system can meet the luminance requirements of actual tunnel lighting, the luminance errors can be controlled less than 2%. Only considering maximum lighting values, the stepless controlled LED lamps can save more than 80% and 35% energy than HPS lamps and LED lamps respectively, and can save more than 20 % energy than four-steps controlled LED lamps.

**Keywords:** automatic control system, tunnel lighting, stepless control method, energy-saving.

## 1 Introduction

China social economy and traffic undertaking are developing rapidly, tunnel traffic is becoming more and more necessary and important in mountainous areas of China, but the operating cost of tunnel traffic is huge, how to improve traffic safety performance and reduce operating cost of the tunnel traffic has become a focus issue that the China's transport department concerned. Tunnel lighting is an indispensable part to ensure driving safety and normal operation in tunnel traffic, and also is a key factor to reduce tunnel interior energy consumption [1]. Therefore, the corresponding design specifications about tunnel lighting are issued in various countries, such as CIE (Commission International d'Eclairage), BS (Britain lighting standards) and IES (Illuminating Engineering Society of North America), etc [2]-[4]. To establish a safe, economical and energy-saving tunnel lighting system has important significance for sustainable development of China's highway engineering.

Design quality of tunnel lighting control system determines whether tunnel lighting design is excellent or not. The existing control methods include manual

---

<sup>1</sup> School of Mechatronic Engineering, East China Jiaotong University Nanchang, P.R. China

control, sequential control and automatic control methods. Manual and sequential control methods are easy to implement and more stable and reliable in practice, but the tunnel interior luminance can be not adjusted along with the changes of weather, traffic volume and vehicle speed, the both methods hardly have any energy-saving effect, as a result, much electric energy is wasted [5]-[6].

Automatic control methods are widely used in modern tunnel lighting system, which can be divided into hierarchically control method and stepless control method according to adjustment continuity of tunnel light. At present, hierarchical control methods are often used in tunnel lighting control system in China before the application of LED (light-emitting diode) lamps in tunnel lighting, but some problems exist in the methods, the main problems are: 1) the automatic control levels can be done only from 2 to 3 because of the limited routing circuit, the parameters of environmental luminance, traffic volume and vehicle speed are only considered with maximum values at design stage, as a result, the lighting luminance of each section in tunnel is always in maximum state, lighting efficiency is evidently low, electric energy consumption is great; 2) the contradictions with driving safety and tunnel monitor arise during the operation course [7]-[8]. In the paper, an automatic control system for tunnel lighting is designed based on the characteristics of LED lamps, especially the characteristics of control easiness compared with other lamps, which made the luminance in tunnel be adjusted dynamically along with the changes of environmental luminance, traffic volume and vehicle speed, and thus continuous tuning of tunnel lighting is achieved. The control system not only ensures operation safety of the tunnel, but also realizes energy-saving.

## **2 Tunnel lighting control strategy**

The control strategy of tunnel lighting system is designed based on “Specifications for Design of Ventilation and Lighting of Highway Tunnel” [9] (hereinafter referred to as the “Design Specifications”), the principle is that the mathematical models of each section in tunnel are established based on the adaptation curve of the luminance in tunnel (as shown in Fig. 1), tunnel exterior environmental luminance, traffic flow and vehicle speed information. In accordance with the established mathematical models, the dynamic dimming control of LED lamps is conducted, and the luminance in tunnel is very close to the adaptation curve, energy-saving is achieved with optimal control effect.

Stepless control is not absolute continuous dimming, but a more refined hierarchical control method. Environmental parameters with maximum values are generally considered in hierarchical control at tunnel lighting design stage, the effect of the changes of environmental parameters is neglected. Sometimes automatic control is achieved only from 2 to 3 levels because of the limited routing circuit. Stepless control is closer to continuous dimming by adopting more refined levels [10].

When planning tunnel lighting, five sections have to be considered: access zone, entrance zone, transition zone, interior zone and exit zone. There are different lighting requirements for different zones. In order to meet requirements of human eyes adaptation to luminance, logarithm dimming method for LED lamps is adopted:

single-lamp 256-grade dimming, so that the whole tunnel lighting looks like a linear regulator dimming. Meanwhile, the threat of driving safety due to abrupt luminance change can be avoided by gradual control method. Triggering light dimming too often is not only conducive to the human eyes adaptability, and to some extent, service time of lamps is also reduced. Time-triggered model is resorted during the control process: information of environmental luminance, traffic volume and vehicle speed is collected and required luminance is calculated at interval of 3~5 minutes.

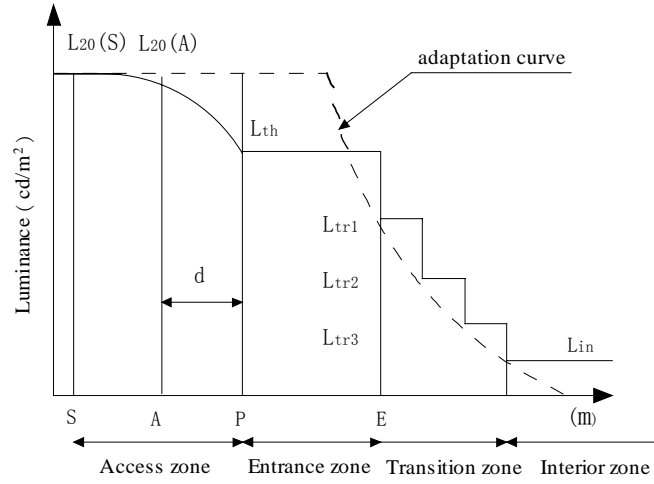

**Fig.1.** Theory demand curve of tunnel lighting.

In this paper, the mathematical models of the luminance of each section in tunnel are established on the data from “Design Specification” by a linear regression.

1) The mathematical model of the entrance zone: one-rank linear regression is adopted in MATLAB to make statistics analysis of the data from “Design Specifications” and fitted regression equations of luminance discount coefficient of the entrance zone are obtained. The luminance discount coefficient of the entrance zone under different traffic volumes and vehicle speeds is calculated by formula (1).

$$k = \begin{cases} 0.0004v - 0.0085 & Q \leq 700 \\ \frac{0.54v + 0.0002Q(v - 1.1) - 12.91}{1700} & 700 < Q < 2400 \\ 0.0006v - 0.0107 & Q \geq 2400 \end{cases} \quad (1)$$

where  $v$  is vehicle speed,  $Q$  is traffic volume.

The luminance of entrance zone is calculated by the formula (2).

$$L_{th} = k \cdot L_{20}(S). \quad (2)$$

where  $L_{th}$  is the entrance zone luminance ( $\text{cd}/\text{m}^2$ );  $L_{20}(S)$  is the tunnel exterior environmental luminance ( $\text{cd}/\text{m}^2$ ).

The entrance zone luminance under different traffic volumes and vehicle speeds is calculated by formula (3).

$$L_{th} = \begin{cases} (0.0004v - 0.0085) \times L_{20}(S) & Q \leq 700 \\ \frac{0.54v + 0.0002Q(v - 1.1) - 12.91}{1700} \times L_{20}(S) & 700 < Q < 2400 \\ (0.0006v - 0.0107) \times L_{20}(S) & Q \geq 2400 \end{cases} \quad (3)$$

2) The mathematical model of the interior zone: the interior zone luminance is relevant to traffic volume and vehicle speed, the tunnel exterior environmental luminance has no effect on it. In order to reduce the luminance calculation error, the second-order linear regression is adopted to fit the interior zone luminance values. The interior zone luminance under different traffic volumes and vehicle speeds is calculated by formula (4).

$$L_{in} = \begin{cases} 0.0013v^2 - 0.135v + 4.95 & Q \leq 700 \\ \frac{158v^2 + 0.09v^2Q - 19534v - 4.88vQ + 4.75Q + 808250}{170000} & 700 < Q < 2400 \\ 0.0022v^2 - 0.1838v + 5.425 & Q \geq 2400 \end{cases} \quad (4)$$

3) The transition zone luminance depends on the entrance luminance. The transition zone is composed of three sections:  $L_{tr1}$ ,  $L_{tr2}$ ,  $L_{tr3}$ , and the corresponding luminance of each section is calculated by  $L_{tr1}=0.3L_{th}$ ,  $L_{tr2}=0.1L_{th}$ ,  $L_{tr3}=0.035L_{th}$ , respectively, according to the ‘‘Design Specifications’’.

4) The exit luminance is five times of the interior zone luminance,  $L_{out}=5L_{in}$ .

## 2 Control system structure

In order to meet the demands of tunnel lighting and energy-saving better, stepless control method is adopted in the tunnel lighting control system. The control system is composed of vehicle detectors, luminance detectors, data converters, lighting control computer, dimming controllers and LED lamps. The structure block diagram is shown in Fig. 2.

Environmental luminance, traffic volume and vehicle speed information are collected by vehicle detectors and luminance detectors. The data converted by data converters from collected information are sent to lighting control computer installed in tunnel control room. According to the predetermined dimming logic in lighting control computer, the luminance of each section in tunnel is calculated, the required dimming values for dimming controllers of each node are calculated in the control

computer in accordance with the preceding luminance calculated and power curve of LED lamps. The control computer sent control commands to dimming controllers, LED lamps power are adjusted by the commands received, and fed relevant information back to lighting control computer, and continuous light tuning of tunnel lighting is achieved.

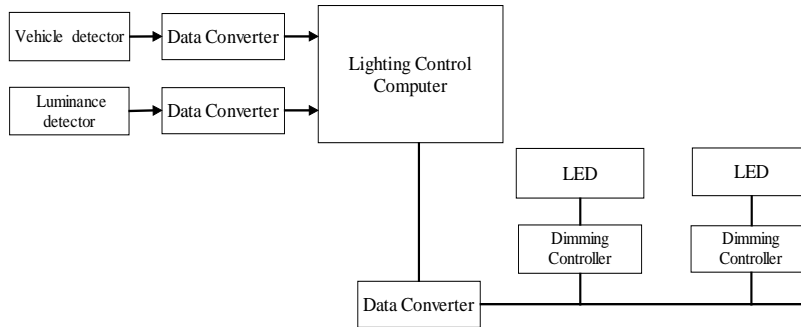

**Fig. 2.** Block diagram of tunnel lighting auto-control.

VCCS (voltage control current source) is adopted in the dimming controllers of tunnel LED lamps. VCCS is output-current controllable power which uses direct current signal voltage to control current output average, the schematic diagram of VCCS is shown in Fig. 3. VCCS directly controls duty factor of primary switch tube of power supply after current-signal's being sampled, isolated and amplified, isolation transformer converts electric energy of different duty factors into direct pulse current, the direct pulse current is filtered by low pass filter and converted into direct current that changes with control signal. In this way, the output current is controlled.

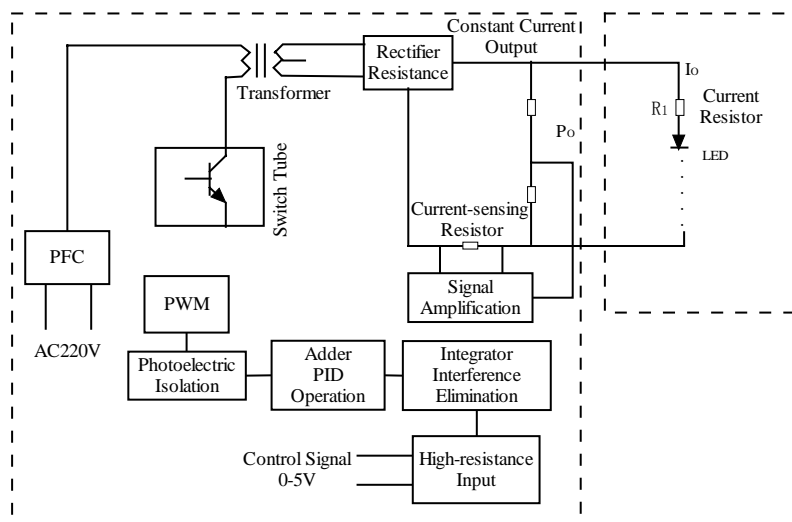

**Fig. 3.** Schematic diagram of VCCS.

## 4 Main control program flow chart

The flow chart of the main tunnel lighting control program is shown in Fig. 4, the steps are as follows:

(1) Initializing sub-modules of the system, reading luminance information and vehicle information, and judging whether the manual control is enabled (the automatic control is implemented by default).

(2) If the automatic control is implemented, judging whether the tunnel is in normal state, if in abnormal state, calling the special control procedures, alarming and ending the program; if in normal state, calling control procedures of automatic dimming directly and outputting control instructions, so one dimming course is completed.

(3) Judging whether the program is stopped by instruction of external trigger, if not, collecting the new data at interval of 3~5 minutes, if yes, ending the program. The mathematical model and control flow are converted into the corresponding control program and embedded in the lighting control computer to realize automatic dimming control of tunnel lighting.

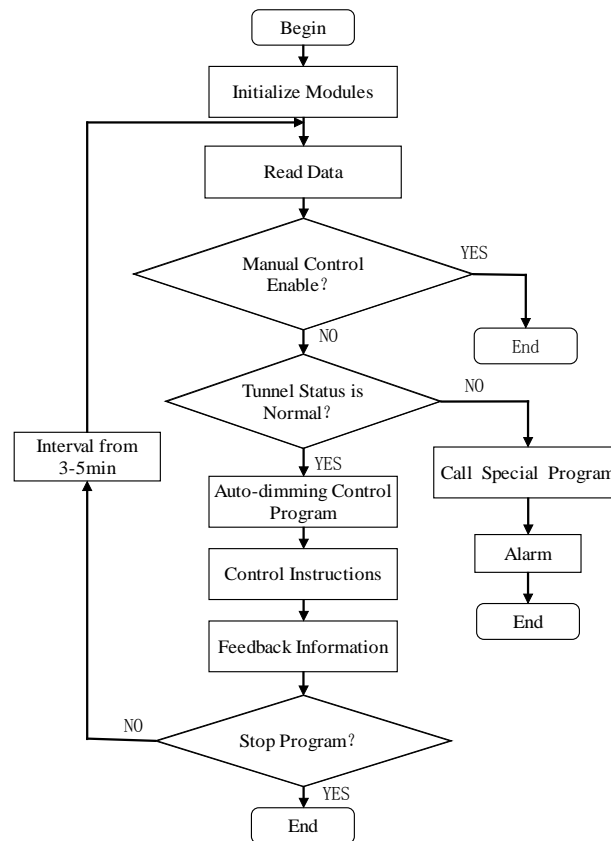

Fig. 4. Flow chart of tunnel lighting control system.

## 5 Simulation

According to the mathematical model and control method, combining with the environmental data, a simulation experiment and analysis is done. Setting parameter values of environmental luminance, traffic volume and vehicle speed in different time range during sunny day, 20 sets of simulation luminance data of each section in tunnel are collected, part data are shown in Table I (only 5 sets of sample data are listed in the paper). The theoretical luminance data of each section in tunnel are calculated according to the established mathematical model and environmental parameters set, 5 sets of data are shown in Table II. Comparing the data of Table I and Table II, the simulation luminance data are very close to the theoretical luminance data, the error range can be controlled at 2%, even less.

Table I. Simulation luminance data (partly).

Exterior luminance ( $\text{cd/m}^2$ )	Traffic volume (vehicles/h)	Vehicle speed (km/h)	$L_{th}$	$L_{tr1}$	$L_{tr2}$	$L_{tr3}$	$L_{in}$	$L_{out}$
4000	500	65	73	21.9	7.3	2.6	1.8	9.0
4000	1000	75	99	29.7	9.9	3.5	2.4	12.0
3000	1500	85	96	28.8	9.6	3.4	3.6	18.0
3000	2500	95	142	42.6	14.2	5.0	7.9	39.5
2000	1500	85	67	20.1	6.7	2.3	4.1	20.5
2000	1000	75	51	15.3	5.1	1.8	2.3	11.5

Table II. Simulation luminance data (partly).

Exterior luminance ( $\text{cd/m}^2$ )	Traffic volume (vehicles/h)	Vehicle speed (km/h)	$L_{th}$	$L_{tr1}$	$L_{tr2}$	$L_{tr3}$	$L_{in}$	$L_{out}$
4000	500	65	70	21	7	2.5	1.7	8.5
4000	1000	75	95	28.5	9.5	3.3	2.2	11
3000	1500	85	97	29.1	9.7	3.4	3.8	19
3000	2500	95	139	41.7	13.9	4.9	7.8	39
2000	1500	85	65	19.5	6.5	2.3	3.8	19
2000	1000	75	48	14.4	4.8	1.7	2.2	11

The maximum value of HPS (high pressure sodium) power curve is normalized (setting to 1), other power curve values are obtained compared with HPS power value. The power curves of tunnel lighting in sunny days are shown in Fig.5. The areas surrounded by the curves and horizontal axis show relative power consumption of different control methods. It can be seen from the graph that 40%~50% energy-saving is achieved by using LED lamps to replace HPS lamps. Energy-saving effect of stepless control to LED lamps is very obvious, compared with HPS lamps and LED lamps only considering maximum lighting value, the energy-saving is more than 80% and 35% respectively. Even compared with 4-steps controlled LED lamps, stepless controlled LED lamps can save more than 20 % energy.

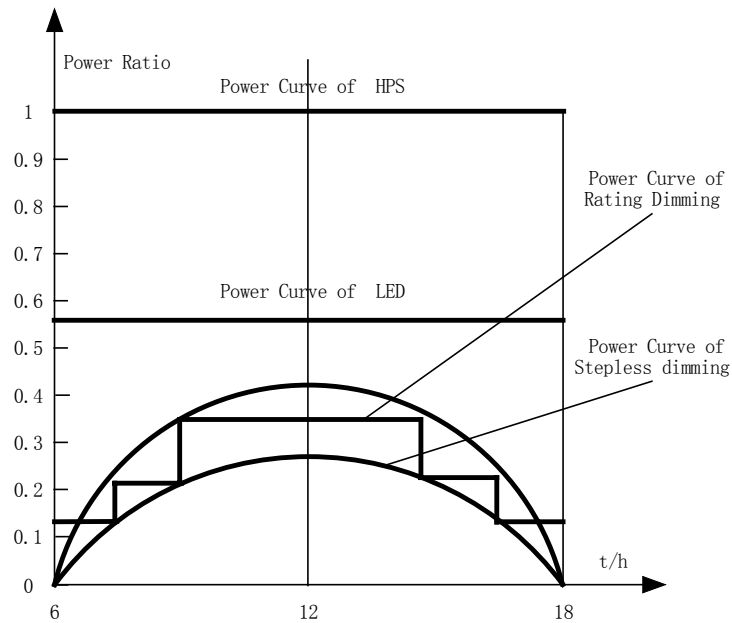

**Fig. 5.** Power curves of tunnel lighting in sunny days.

## 6 Conclusion

Tunnel lighting is an important component of highway traffic; its primary function is to ensure driving safety and comfort during both daytime and nighttime in tunnel. However, energy-saving is also great of importance and cannot be neglected. In this paper, an automatic control system of tunnel lighting is designed based on superior performance of LED lamps and stepless control. The designed control system can meet the lighting requirements very well and overcome the problem of large electricity waste caused by traditional lighting control methods. The impact of the changes of environmental luminance, traffic flow and vehicle speed is considered, continuous dimming of tunnel lighting is achieved, and energy-saving effect is remarkable.

**Acknowledgements.** This work is supported by Key Laboratory of Ministry of Education for Conveyance and Equipment (East China Jiaotong University).

## References

1. D.A. Schreuder: "Road Lighting for Safety", London: Thomas Telford Publishing (1998)



2. Commission Internationale de L'Eclairage: "CIE No88-2 Guide for the Lighting of Road Tunnels and Underpasses", Vienna: CIE Publication(1999)
3. Illuminating Engineering Society of North America: "ANSI/IESNA RP-22-96 American National Standard Practice for Tunnel Lighting", Washington: American National Standards Institute(1996)
4. British Technical Committee: "BS 5489-2 Code of practice for the design of road lighting - Lighting of tunnels", London: British Standards Institution(2003)
5. T.S. Huang and F. Luo: "Energy saving tunnel lighting system based on PLC", 2006 China International Conference on Electricity Distribution (CICED 2006), Beijing, China, pp. 527-533(2006) (in Chinese).
6. S. Nagai, S. Ishida, M. Shinji and K. Nakagawa: "Energy-saving lighting system for road tunnel", Underground Space Use: Analysis of the Past and Lessons for the Future, Istanbul, Turkey, pp. 625-631(2005)
7. R. Li, D. Fu, Z.Y. Chen: "Energy-saving & Control of Tunnel Illumination", Highway Engineering, Vol. 32, No. 5, pp. 204-206(2007) (in Chinese).
8. H. Zhi: "Research on illumination energy saving technique of highway tunnel" 2006 China International Conference on Operation Management and Safety of highway Tunnel, Chongqin, China, pp. 343-347(2006) (in Chinese).
9. Ministry of Communications Highway Scientific Research Institute: "JTJ 026.101999 Specifications for Design of Ventilation and Lighting of Highway Tunnel", Beijing: China Communications Press(2000)
10. X.F. Lv: "The Application of Stepless Intelligent Control System to LED Illuminating Brightness in Tunnel", China Lighting, No. 10, pp. 96-98(2008) (in Chinese).