

A STUDY ON USING AD5933 TO REALIZE SOFT-SENSING MEASUREMENT OF CONDUCTANCE AND CAPACITANCE

Chuanjin Cui¹, Haiyun Wu², Yueming zuo^{1,*}

¹ College of Engineering and Technology, Shanxi Agricultural University, Taigu, Shanxi Province, P. R. China 030801

² College of Engineering and Technology, Shanxi Agricultural University, Taigu, Shanxi Province, P. R. China 030801

* Corresponding author, Address: College of Engineering and Technology, Shanxi Agricultural University, Taigu 030801, Shanxi Province, P. R. China, Tel: +86-0354-6288400-8305, Email: Zyeming88@Yahoo.com.cn

Abstract: A conductance and capacitance test system was designed in this paper. AD5933 a new chip for impedance testing was used in it. By designing the test system, and testing the impedance of a model, which is a resistor in parallel with a capacitor, under different frequency (range from 1000Hz to 100kHz). The information of impedance, real part, and imaginary part of the model under the frequency points were get. Based on this, the internal relations between conductance, capacitance, impedance, real part and imaginary part were carefully analyzed, using the soft-sensing method established the capacitance support vector machine (SVM) regression model on MATLAB. The regression model is the relation between resistance, impedance and capacitance. The test results showed that the test relative error is small in the capacitance range (0.1 pf~33 pf) and the conductance range ($9.05 \times 10^{-3} \text{s} \sim 3.8 \times 10^{-5} \text{s}$), the biggest, smallest and average test error of capacitance are -2.9%, 0.2%, 1.27% respectively. The study showed that using AD5933 and the soft-sensing method to realize the multi-parameter test is feasible.

Keywords: AD5933, conductance, capacitance, soft-sensing measurement, support vector machine

1. INTRODUCTION

Conductance and capacitance are very important electrical parameters, the wide use of them in the agricultural materials nature test will promote the development of agricultural modernization and automation, so the research of their test methods has an important practical significance. However, in the actual measurement, resistance and capacitance are usually coupled together, Expressed as a parallel system of resistance and capacitance, because capacitance measurement is always affected by temperature, parasitic capacitance, dielectric medium leakage resistance, so it is difficult to measure it accurately. There are four traditional methods of capacitance measurement just as follows:

Resonance method. The shortcomings of this approach are the distributed capacitance of wire and coil has a big effect on the measurement results. In addition, the method can not realize automatic measurement, and can not apply to online measurement. (Xiangjun Z et al., 2001).

Oscillometry method. This method was divided into two types, RC Oscillation and LC Oscillation. The former ability in anti-parasitic capacitance is poor, the stability of oscillation frequency is poor too, the sensitivity of small capacitance changes is low. While the latter test range is from a few hundred kHz to several hundred MHz, suitable for high-loss materials capacitance measurement. (Zeljko I et al., 2005).

Alternating current bridge method. This method will have a larger non-linear when test in a point far away from the equilibrium position, the output impedance is high, the output voltage is very small, so it is difficult to measure. In addition, this method needs manual adjustment, the operation is too complex. (Wanguo Liu et al., 2005; Inglis A D et al.,2003).

Charge-discharge method. In this method of measurement the parasitic capacitance has a serious effect on the results. (Sell B et al., 2002).

These commonly used capacitance measurement methods have some weak points as mentioned above. Therefore, it is necessary to study new ways to achieve accurate capacitance measurements in the case of RC coupling.

This paper aims to solve the capacitance measurement in the case of RC coupling, we used AD5933, a new chip for impedance testing, produced by the American company Analog Devices in the year 2005. By designing test circuit, using anti-interference measures, such as shielding and grounding to improve the accuracy and stability of the test system,

At the same time, soft-sensing technique was also applied in the capacitance measurement. Soft-sensing technique, also known as soft instrumentation technology (MCAVOY TJ et al., 1992). That is to measure the variables which are easy to measure and relevant to the measured which

are hard to measure directly, and based on the mathematical relationships between easily measured variables and the measured to complete the inference and estimation of the measured. In this paper soft-sensing technique was used, the support vector machine (SVM) regression mathematical model of resistance, impedance and capacitance was established on MATLAB platform, the capacitance measurement was realized. (Huichun Liu et al., 2002).

2. THE DESIGN OF HARDWARE CIRCUIT

2.1 The measurement principle

AD5933 has a voltage output pins Vout Fig.1. It issued a certain frequency sinusoidal scanning signals to external impedance $z(\omega)$ for incentives. After going through the sample the signal was amplified, filtered, sampled by the ADC, then using discrete Fourier transform to process the data, and calculate the impedance. The sinusoidal scanning signals were generated by the DDS (direct digital synthesizer) a internal part of chip AD5933, and has a resolution of less than 1Hz. Clock frequency provided for the DDS can be generated by external passive oscillator or inner active oscillator, Fig.1. Signals synthesized by DDS were processed by digital-to-analog conversion and amplification, then the signals can be used as the needed scanning and incentives signals.

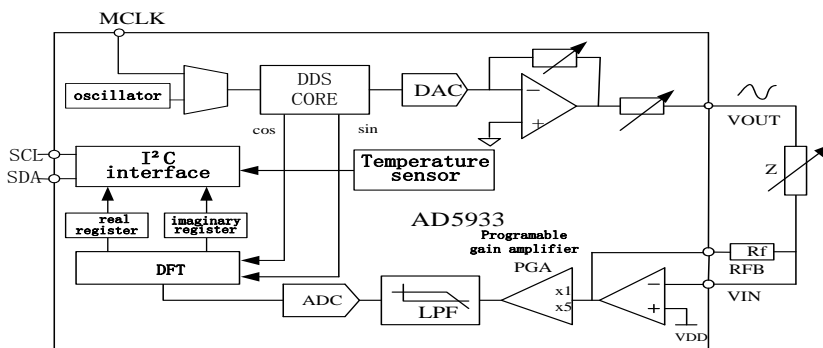

Fig.1: Function structure diagram

After going through the test material, then the scanning incentive signals were amplified, filtered, A/D converted to transform to digital signals. The

output digital signals from A/D converter were processed by Discrete Fourier Transform (DFT), the formula is as follows:

$$X(f) = \sum_{n=0}^{1023} (x(n)(\cos(n) - j \sin(n))) \quad (1)$$

Where f is the frequency of scanning points, $x(n)$ is the output of A/D converter, $\cos(n)$ and $\sin(n)$ were generated by DDS at the frequency f . The calculation results of $X(f)$ is generally a complex number, with a real part R and imaginary part I . These are the easy measured variables. The measured impedance module Magnitude and the phase angle Phase can be calculated by the following formulas:

$$Magnitude = \sqrt{R^2 + I^2} \quad (2)$$

$$phase = \text{Tan}^{-1}\left(\frac{I}{R}\right) \quad (3)$$

So we can get the following test methods. First measure a known impedance, get its R and I , and calculate the Magnitude, then to obtain a gain factor using the following formula. This is the so-called calibration process.

$$gain \cdot factor = \frac{\left(\frac{1}{impedance}\right)}{Magnitude} \quad (4)$$

After getting the gain factor, it becomes bridge of solving the impedance test. It is clear that the mathematical formula should be (5). By measuring the unknown impedance we get the R and I , then get them into formula (2) and (3), we can calculate the unknown impedance.

$$impedance = \frac{1}{(gain \cdot factor \times Magnitude)} \quad (5)$$

Then according to (6) (7)

$$\frac{1}{impedance} = admittance = G + jBc = \frac{1}{R} + j\omega c \quad (6)$$

$$\tan^{-1}\left(\frac{Bc}{G}\right) = -phase = -\text{Tan}^{-1}\left(\frac{I}{R}\right) \quad (7)$$

So the conductance G can be calculated out.

2.2 Impedance measurement circuit

Fig. 2 is the circuit diagram of impedance test using AD5933. In the figure the parallel circuit composed of R_x and C_p is the model need to be measured, the test system was controlled by PC. ADP3303 provide a stable supply voltage of 3.3v to AD5933. There are two ways to provide a clock frequency for the AD5933. one is as shown in Fig.2 the external passive oscillator clock will provide a reliable external clock frequency 16MHZ for the system, the other is as shown in Fig.1 the inner active oscillator provide a reliable frequency 16.776MHZ for the system. By choosing the item in the control interface Fig.4, we select the internal clock frequency. The measured data of impedance Z , R and I were downloaded to the PC for preservation through the USB interface.

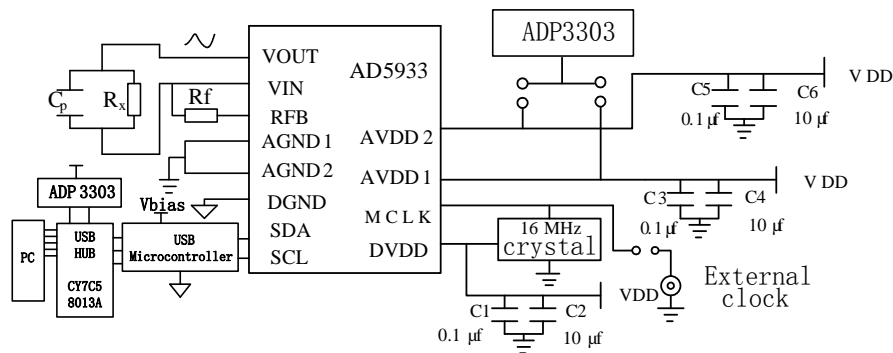

Fig.2 Test circuit diagram

3. MEASUREMENT OF CONDUCTANCE AND CAPACITANCE

3.1 Conductance measurement

In the test, we use paprallel structure of different resistors and capacitors as test objects. Tested 210 different combinations composed by 7 different resistors and 30 different capacitors.

In order to get a greater change in impedance by making a small change in the capacitance, that is to use the easily measured variables to accurately reflect the measured capacitance value, so in the design of parallel coupling model, first we did the theoretical calculations on the MATLAB software and found that when R_x is around $500K\Omega$ and C_p around $30pf$ will meet the requirements. Given

laboratory conditions, we designed a parallel model as shown in Fig.3 (Rx in parallel with Cp), where Rb is 512.2K, C1 is 11.1pf, C2 is 20.6pf, while the variable resistor r and the variable capacitor c is the value we want to measure, all the metal film resistors have an accuracy of 1%, and all the ceramic capacitors have an accuracy of 10%, their values were measured by a resistance and capacitance meter UNI-T ® UT601 (accuracy: $R \pm (0.8\% + 1)$, capacitance $\pm (1\% + 5)$) produced by You li de company for comparison.

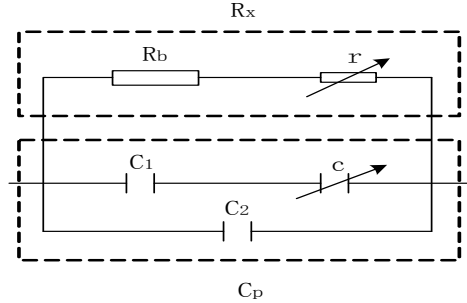

Fig.3 parallel coupling model of resistor and capacitor

Access the test system to a computer through USB, and open the control interface, estimating the value of the impedance to be tested, program frequency sweep parameters into relevant registers, and choose appropriate impedance Z and the feedback resistor Rf Fig.2 to calibrate the system, and then got the gain factor. make sure that the ratio of Rf/Z maintained between 0.2 and 0.066, this is because the highest voltage of the internal A/D converter is 2V calculated from the following Formula Fig.1. In order to let the A/D converter work in linear area, it should be no more than 2V, so the

$$V_{out} \times \frac{R_f}{Z} \times PGA$$

ratio of Rf/Z should be maintained between 0.2 and 0.066. In this test we adopted one impedance test range(150 kΩ~200 kΩ), the calibration value r is 2.403 kΩ and c is 7.9 pf Fig.3, Rf is 18.37 kΩ.The rest parameters setting by control interface Fig.4 are as follows: start frequency is 30000Hz, delta frequency is 5Hz, number of increments is 300, number of setting time cycle is 15. PGA value is 5, scanning voltage is 2vp-p, and 16776000Hz internal clock frequency.

We tested 210 different combinations which composed by 7 different resistors r and 30 different capacitors c. After getting the data of impedance, real and imaginary parts under the frequency point 30kHz, the conductance can be calculated by formula (6) and (7), then made a comparison with the value measured by UT601 in Table1.

Table 1. conductance value

UT601 measured value (mS)	9.05	1.623	0.664	0.417	0.194	0.100
measured value (mS)	8.834	1.647	0.653	0.431	0.193	0.101
Relative error (%)	2.39%	1.66%	1.66%	-3.36%	0.52%	-1%

In addition, this experiment was carried out in the environmental temperature 20 °C, so there is no need to make temperature compensation.

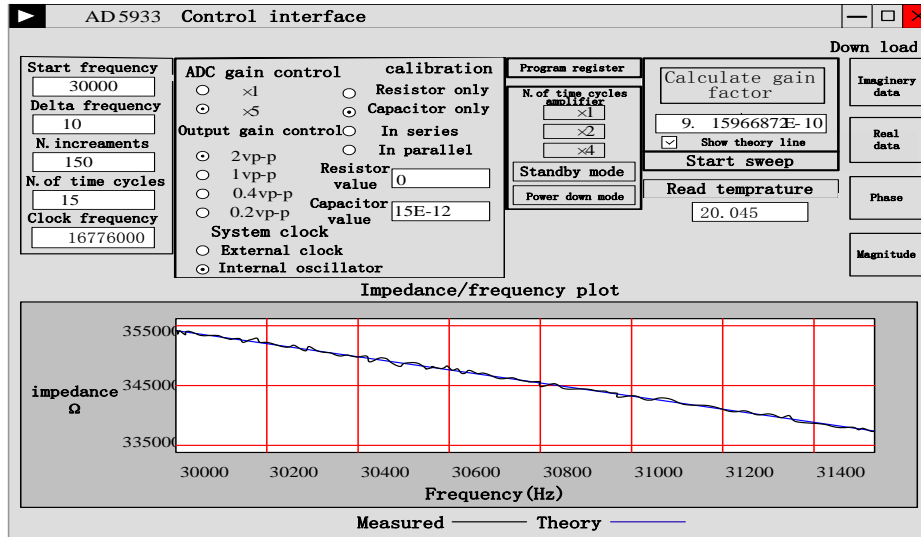

Fig.4 Control interface

3.2 Capacitance measurement

A svm loop program was established on the matlab platform, that is the two elements regression model, Using 140 sets of data (resistance r, impedance Z and capacitance c) from the 210 sets of data to training the two elements support vector machine (SVM) capacitance regression model, by adjusting the relaxation factor, the optimization model was selected and use the model to predict capacitance in the 70 remaining data sets, the result was good, parts of the data were shown in Table2.

Table 2. capacitance value

UT601	0.7	1.1	1.5	3.3	4.9	5.1	6.5	10.8	12.5	15.4	18.1	21.8	25.7	33	41.4
-------	-----	-----	-----	-----	-----	-----	-----	------	------	------	------	------	------	----	------

measured value(pf)															
Predicted Values(pf)	0.71	1.09	1.54	3.35	4.94	5.07	6.59	11.03	12.55	15.56	18.48	21.71	25.65	33.96	41.69
Relative error(%)	-1.4	0.9	-2.7	-1.5	-0.8	0.6	-1.4	-2.1	-0.4	-1.0	-2.1	0.4	0.2	-2.9	-0.7

3.3 Results and discussion

The measured conductance value was the value calculated from the measured impedance, real part and imaginary part. Seen from Table 2, the biggest relative error of measurement is -3.36%, the smallest is 0.52% and the average relative error is 1.86%, and meets the testing requirements.

For the capacitance measurement, after calculating the conductance, a two elements support vector machine (SVM) capacitance regression model was established by using 140 sets of data (resistance r , impedance Z and capacitance c), and trained the model several times, then use it to predict the capacitance, choose 15 predict capacitance results at random. As shown in Table 2, and can be seen from the table, the biggest relative error is -2.9%, the smallest is 0.2% and the average relative error is 1.27% compared with the conductance measurement the error is obviously low, in theory, the capacitance is calculated on the base of conductance, the error should be increased, but the actually it is reduced, that is because of the support vector machine (SVM) model and its ability in data processing. SVM have a solid theoretical foundation, it can establish a good model by a small sample set, after training the model, it will have a good prediction capability, it's strong robust can reduce random error and the effect caused by structural error, further improved the accuracy and had the advantages which Neural network does not have.

4. CONCLUSION

As AD5933 integrated the hardware (circuit) and the signal processing, use it to compose the test system can save a lot external circuits as well as software cost, and the test operation is easy, and AD5933 also has a merit of strong function, low prices and able to test online, has a broad application prospects. The measurement system composed with AD5933 can not only the complete the test of impedance, phase angle, but also can complete the measurement of conductance and capacitance. A single chip achieved a multi-parameter measurement. In addition, SVM plays a very important part in improving the measurement accuracy. The combination of AD5933 test

systems and SVM regression model successfully applied in conductance and capacitance measurement. This is the foundation for the manufacture of related portable test instruments, at the same time, the test method can be applied to test the agricultural materials conductance and capacitance.

ACKNOWLEDGEMENTS

This work is supported by a research grant from the National Science Foundation, NSF 30871445.

REFERENCES

- Xiangjun Z, Xianggen Y, Deshu C. A novel technique for measuring rounding capacitance and grounding fault resistance in ineffectively grounded systems, *Power Engineering Review*, 2001, 21(3):65-67
- Zeljko I, Mark F. An interface circuit for measuring capacitance changes based upon capacitance-to-duty-cycle (CDC) Converter, *IEEE SENSORS JOURNAL*, 2005, 5(3):403-410
- LIU Wan-guo, YANG Gong-liu, XIAO Qian. Application of Small Capacitance Measuring Techniques in Gravimeter, *Journal of Chinese Inertial Technology*, 2005, 13(1):68-71 (in Chinese)
- Inglis A D, Wood B M, Cote M et al. Direct determination of capacitance standards using a quadrature bridge and a pair of quantized hall resistors, *IEEE Trans. On Instrumentation and Measurement*, 2003, 52(2): 559-562
- Sell B, Avellan A, Krautschneider W H. Charge-based capacitance measurements (CBCM) on MOS devices, *IEEE Trans. on Device and Materials Reliability*, 2002, 2(1):9-12
- MCAVOY T J. Contemplative Stance for Chemical Process Control, *Automatica*, 1992, 28(2):441-42
- Huichun Liu, Shuyuan Ma. Present situation of SVM, *Journal of Image and Graphics*, 2002, 7(6):618-623 (in Chinese)